



Online Data Validator User's Manual

Thermal and RFID Printers

Software License Agreement

CAREFULLY READ THE FOLLOWING TERMS AND CONDITIONS BEFORE USING THIS PRINTER. USING THIS PRINTER INDICATES YOUR ACCEPTANCE OF THESE TERMS AND CONDITIONS. IF YOU DO NOT AGREE TO THESE TERMS AND CONDITIONS, PROMPTLY RETURN THE PRINTER AND ALL ACCOMPANYING HARDWARE AND WRITTEN MATERIALS TO THE PLACE YOU OBTAINED THEM, AND YOUR MONEY WILL BE REFUNDED.

Definitions.

“Software” shall mean the digitally encoded, machine-readable data and program. The term “Software Product” includes the Software resident in the printer and its documentation. The Software Product is licensed (not sold) to you, and Printronix Auto ID Technology, Inc. either owns or licenses from other vendors who own, all copyright, trade secret, patent and other proprietary rights in the Software Product.

License.

1. Authorized Use. You agree to accept a non-exclusive license to use the Software resident in the printer solely for your own customary business or personal purposes.
2. Restrictions.
 - a. To protect the proprietary rights of Printronix Auto ID Technology, Inc., you agree to maintain the Software Product and other proprietary information concerning the typefaces in strict confidence.
 - b. You agree not to duplicate or copy the Software Product.
 - c. You shall not sublicense, sell, lease, or otherwise transfer all or any portion of the Software Product separate from the printer, without the prior written consent of Printronix Auto ID Technology, Inc.
 - d. You may not modify or prepare derivative works of the Software Product.
 - e. You may not transmit the Software Product over a network, by telephone, or electronically using any means; or reverse engineer, decompile or disassemble the Software.
 - f. You agree to keep confidential and use your best efforts to prevent and protect the contents of the Software Product from unauthorized disclosure or use.
3. Transfer. You may transfer the Software Product with the printer, but only if the recipient agrees to accept the terms and conditions of this Agreement. Your license is automatically terminated if you transfer the Software Product and printer.

Limited Software Product Warranty

Printronix Auto ID Technology, Inc. warrants that for ninety (90) days after delivery, the Software will perform in accordance with specifications published by Printronix Auto ID Technology, Inc. Printronix Auto ID Technology, Inc. does not warrant that the Software is free from all bugs, errors and omissions.

Remedy

Your exclusive remedy and the sole liability of Printronix Auto ID Technology, Inc. in connection with the Software is replacement of defective software with a copy of the same version and revision level.

Disclaimer of Warranties and Limitation of Remedies

1. THE PARTIES AGREE THAT ALL OTHER WARRANTIES, EXPRESS OR IMPLIED, INCLUDING WARRANTIES OF FITNESS FOR A PARTICULAR PURPOSE AND MERCHANTABILITY ARE EXCLUDED.
Printronix Auto ID Technology, Inc. does not warrant that the functions contained in the Software will meet your requirements or that the operation of the Software will be uninterrupted or error free. Printronix Auto ID Technology, Inc. reserves the right to make changes and/or improvements in the Software without notice at any time.
2. IN NO EVENT WILL PRINTRONIX AUTO ID TECHNOLOGY, INC. BE LIABLE FOR LOST PROFITS, LOST DATA, BUSINESS INTERRUPTIONS, OR ANY OTHER DIRECT, INDIRECT, INCIDENTAL OR CONSEQUENTIAL DAMAGES ARISING OUT OF THE USE OF OR INABILITY TO USE THIS PRODUCT, EVEN IF PRINTRONIX AUTO ID TECHNOLOGY, INC. HAS BEEN ADVISED OF THE POSSIBILITY OF SUCH DAMAGES, OR ANY DAMAGES CAUSED BY THE ABUSE OR MANIPULATION OF THE SOFTWARE. SOME STATES DO NOT ALLOW THE EXCLUSION OR LIMITATION OF LIABILITY FOR CONSEQUENTIAL OR INCIDENTAL DAMAGES, SO THE ABOVE LIMITATION MAY NOT APPLY TO YOU.
3. Printronix Auto ID Technology, Inc. will not be liable for any loss or damage caused by delay in furnishing a Software Product or any other performance under this Agreement.
4. Our entire liability and your exclusive remedies for our liability of any kind (including liability for negligence except liability for personal injury caused solely by our negligence) for the Software Product covered by this Agreement and all other performance or nonperformance by us under or related to this Agreement are limited to the remedies specified by this Agreement.
5. California law governs this Agreement.

Termination of License Agreement

This License shall continue until terminated. This license may be terminated by agreement between you and Printronix Auto ID Technology, Inc. or by Printronix Auto ID Technology, Inc. if you fail to comply with the terms of this License and such failure is not corrected within thirty (30) days after notice. When this License is terminated, you shall return to the place you obtained them, the printer and all copies of the Software and documentation.

U.S. Government Restricted Rights

Use, duplication or disclosure by the Government is subject to restrictions as set forth in the Rights in Technical Data and Computer Software clause at FAR 242.227-7013, subdivision (b) (3) (ii) or subparagraph (c) (1) (ii), as appropriate. Further use, duplication or disclosure is subject to restrictions applicable to restricted rights software as set forth in FAR 52.227-19 (c) (2).

Acknowledgement of Terms and Conditions

YOU ACKNOWLEDGE THAT YOU HAVE READ THIS AGREEMENT, UNDERSTAND IT, AND AGREE TO BE BOUND BY ITS TERMS AND CONDITIONS. NEITHER PARTY SHALL BE BOUND BY ANY STATEMENT OR REPRESENTATION NOT CONTAINED IN THIS AGREEMENT. NO CHANGE IN THIS AGREEMENT IS EFFECTIVE UNLESS WRITTEN AND SIGNED BY PROPERLY AUTHORIZED REPRESENTATIVES OF EACH PARTY. BY USING THIS PRINTER, YOU AGREE TO ACCEPT THE TERMS AND CONDITIONS OF THIS AGREEMENT.

Communication Notices

This equipment has been tested and found to comply with the limits for a Class B digital device, pursuant to Part 15 of the FCC Rules. These limits are designed to provide reasonable protection against harmful interference in a residential installation. This equipment generates, uses, and can radiate radio frequency energy and, if not installed and used in accordance with the instructions, may cause harmful interference to radio communications. However, there is no guarantee that interference will not occur in a particular installation. If this equipment does cause harmful interference to radio or television reception, which can be determined by turning the equipment off and on, the user is encouraged to try to correct the interference by one or more of the following measures:

- Reorient or relocate the receiving antenna.
- Increase the separation between the equipment and receiver.
- Connect the equipment into an outlet on a circuit different from that to which the receiver is connected.
- Consult the dealer or an experienced radio/TV technician for help.

Unauthorized changes or modifications could void the user's authority to operate the equipment.

This device complies with part 15 of the FCC Rules. Operation is subject to the following two conditions: (1) this device may not cause harmful interference, and (2) this device must accept any interference received, including interference that may cause undesired operation.

Any change or modification to this product voids the user's authority to operate it per FCC Part 15 Subpart A Section 15.21 regulations.

Canada

This Class B digital apparatus complies with Canadian ICES-003 and RSS 210.

Cet appareil numérique de la classe B est conforme à la norme NMB-003 du Canada.

Operation is subject to the following two conditions: (1) this device may not cause interference, and (2) this device must accept any interference, including interference that may cause undesired operation of the device.

CE Notice (European Union)

Marking by the CE symbol indicates compliance of this Printronix system to the EMC Directive and the Low Voltage Directive of the European Union. Such marking is indicative that this Printronix system meets the following technical standards:

- EN 55022 — “Limits and Methods of Measurement of Radio Interference Characteristics of Information Technology Equipment.”
- EN 55024 — “Electromagnetic Immunity Requirements for Information Technology Equipment”
- EN 60950 — “Safety of Information Technology Equipment.”

Printronix Auto ID Technology, Inc. cannot accept responsibility for any failure to satisfy the protection requirements resulting from a non-recommended modification of the product, including the fitting of non-Printronix option cards.

This product has been tested and found to comply with the limits of Class A Information Technology Equipment according to European standard EN 55022. The limits for Class A equipment were derived for commercial and industrial environments to provide reasonable protection against interference with licensed communication devices.

WARNING

This is a Class A product. In a domestic environment this product may cause radio

CE Symbol



Taiwan

經型式認證合格之低功率射頻電機，非經許可，公司、商號或使用者均不得擅自變更頻率、加大功率或變更原設計之特性及功能。

低功率射頻電機之使用不得影響飛航安全及干擾合法通信；經發現有干擾現象時，應立即停用，並改善至無干擾時方得繼續使用。前項合法通信，指依電信法規定作業之無線電通信。低功率射頻電機須忍受合法通信或工業、科學及醫療用電波輻射性電機設備之干擾。

Printronix Auto ID Technology, Inc. makes no representations or warranties of any kind regarding this material, including, but not limited to, implied warranties of merchantability and fitness for a particular purpose. Printronix Auto ID Technology, Inc. shall not be held responsible for errors contained herein or any omissions from this material or for any damages, whether direct, indirect, incidental or consequential, in connection with the furnishing, distribution, performance or use of this material. The information in this manual is subject to change without notice.

This document contains proprietary information protected by copyright. No part of this document may be reproduced, copied, translated or incorporated in any other material in any form or by any means, whether manual, graphic, electronic, mechanical or otherwise, without the prior written consent of Printronix Auto ID Technology, Inc.

COPYRIGHT © 2016 PRINTRONIX AUTO ID, INC. All rights reserved.

Trademark Acknowledgements

T6000, T8000 are trademarks of Printronix Auto ID Technology, Inc.

Printronix Online Data Validator (ODV) Compliance Statement

The Printronix Online Data Validator gathers data per the ISO/ANSI method of verification to perform practically all the industry standard bar code quality parameter calculations. These include all ISO/ANSI method parameters, PCS, ratio, X dimension calculation, modulo check digit calculations, average bar deviation, etc., along with decoding the symbol.

Reflectance Compliance – 660 nm Wavelength (Red) Light

The reflectance values embedded in the calibration symbol supplied with each ODV are traceable to Applied Image Primary Verification Calibrated Standard per ANSI X3.182 Step Reflectance Chart (see note 2.) Applied Image certified Calibration Standards are manufactured to Applied Image, Inc. and Uniform Code Council, Inc. specifications, using ANSI X3.182-1990 methodology, and are calibrated using standards traceable to the National Institute of Standards and Technology (N.I.S.T.)

ISO/ANSI Method Compliance

The Printronix ODV gathers data and performs all ISO/ANSI method parameter calculations per the ISO/IEC 15416 and ANSI X3.182-1990 methodologies with a few special considerations and exceptions. The ODV also conforms to ISO/IEC 15426 per the requirements specified in Section 2. The exceptions and considerations are related to the instrument's design and mission. The design incorporates a proprietary analog laser scanner that can be assembled with various focus lengths to produce different beam spot sizes. The mission is to not only analyze bar code quality, but also to detect any printer failures, process failures or media problems. For maximum performance and to conform to quality specifications, a fixed mounting distance and angle are required. A beam spot size able to detect errors of the particular print method is highly recommended. This beam spot size used may or may not correspond to the recommendations in various specifications that it be related to the X dimension of a particular symbol, but instead correspond to the printer's resolution or some other parameter(s) critical in the application. A major philosophy of an on-line verification system is; if the printer and/or process is operating correctly and the media has proper reflectance properties, the best print quality for that particular print method and material is achieved by definition.

Special Considerations

1. Final system tests are performed at the proper focus distance and at an angle of 22 degrees. Units with common focus distances are checked to yield analysis results within +/- 4 % of all target values except +/- 3% for the Rmin calculation.
2. The standard ODV has an 8-inch focus distance creating a spot size that gathers light equivalent to a 6 mil round aperture. For these models, final test includes analyzing UPC symbols on the Calibrated Conformance Standard Test Card for EAN/UPC Symbol Verifiers. Results are checked to be within +/- 4% (+/- 3% for Rmin) of the marked values on the test card.
3. All ODV's use the same laser diode with a wavelength of 660 +/- 10 nm. Therefore, any ISO/ANSI overall symbol grade calculated by an ODV includes 660 as the wavelength portion of the grade.

Exceptions to the ISO/ANSI Method

1. The Defects calculation does not include the quiet zone area. A separate quiet zone check is implemented to more easily isolate print problems vs. setup problems in an on-line environment.
2. A laser spot is used instead of a round aperture. The spot size is dependent on the focus distance of the unit's optical system.

Table of Contents

1	Installation Instructions	12
	Overview	12
	Differences Between T8000 and T6000 Models	12
	Operational Parameters	12
	Tools and Materials Needed	13
	Parts List	13
	Safety Notices	14
	T6000 Installation and Removal	15
	Prepare the Printer	15
	Factory Installation	15
	Field Installation	15
	Remove the Side Cover	15
	Routing the Power/Data Cable	16
	Installing the ODV Interface PCBA	17
	Install the Validator	18
	Attach the Power/Data Cable	19
	T8000 Installation and Removal	20
	Prepare the Printer	20
	Factory Installation	20
	Field Installation	20
	Install the Ferrite	20
	Install the Validator	29
	Attach the Power/Data Cable	32
	Restore the Printer to Operation	34
	Enable the Validator	34
	Adjust the Scanning Beam	35
	Continuous, Tear-Off, and Tear-Off Strip	35
	Peel-Off Media Handling Mode	36
	Cut Media Handling Mode (T8000 only)	37
	Scanning Beam Vertical Alignment	39
	Scanning Beam Skew Adjustment	39
	Shifting the Scanning Beam	39
	Calibration	39
	Bar Code Validation Demo Page	41
2	Operation	42
	Basic Validator Setup	42
	Unit Positioning	42
	Validator Front Panel	42
	Validator Menu 	43

Configuring  the Validator	44
Enabling and Disabling the Validator	44
RFID Encoder	44
Checking the Firmware Revision Number	45
Validator Reporting	45
Requesting a Validator Report.....	45
Defining the Output Destination (Telemetry Path).....	45
Selecting the Type of Report (Telemetry Data)	45
Resetting Validator Data	45
Control Submenu	46
Validator Active	46
Auto Report.....	46
Auto Report Time.....	47
Telemetry Path.....	47
Return Data.....	48
Telemetry Data	48
Number of Codes.....	48
Validator Action.....	49
Quiet Zones.....	50
Min. Code Height	50
Min. Code Gap.....	50
Skip Labels.....	51
Overstrike Style.....	51
l2of5 Checksum	51
Num Retry.....	52
Num Rescan (T8000 only).....	52
Max Retry Action.....	52
Label Save	53
Comm Error.....	53
Verify Start	54
Verify Stop.....	54
Grading Submenu.....	55
Decodability.....	55
Percent Decode	55
Defects.....	55
Overall Grade.....	56
Modulation.....	56
EC Min	57
RMin.....	57
Symbol Contrast	57
Overall Grade Calculations	57
Scanner Submenu	58

Gain.....	58
Offset.....	59
SN Threshold	59
Min. Read Scans.....	60
Beam Width.....	60
Beam Shift.....	61
Diagnostics Submenu	61
Scan Report	61
Scan Report Information	62
Scan Profile.....	63
Profile Horiz Mag	63
Print Settings.....	64
Scanner Settings.....	66
Statistics Submenu	67
Clear Data	67
Good Barcodes	67
Good Forms	67
Overstrike Forms	67
Average BWD	67
Last BWD	67
Validator F/W	68
Operation	68
Print Speed Limits.....	68
Min. Code Height (Bar Code Height	68
Min. Code Gap.....	69
On-Demand Printing	69
Bar Code Failures.....	70
Process for Barcode Analysis	70
Bad Bar Code Error Detection	71
Missing Bar Code Error Detection	71
Validator Action (Error Action)	71
Stop.....	72
Overstrike.....	72
Retry Form	72
Stop & Retry.....	73
Grade&Report.....	73
Rescan Form (T8000 only)	73
Rescan&Retry (T8000 only).....	74
Rescan&Stop (T8000 only).....	74
Error Messages.....	75
Troubleshooting.....	79
Maintenance	81

A Contact Information82
Printronic Customer Support Center 82
Corporate Offices 83

1 *Installation Instructions*

Overview

The online data validator (ODV) is an external bar code scanning device attached above the paper exit of the printer. When activated, it scans the printed output looking for bar codes. When it finds a bar code, it determines what type of bar code it is and monitors the bar code quality as it passes through the scan area.

After the entire bar code has passed under the scanning beam, the validator grades the bar code and sends a report to the printer. How the printer responds is determined by the validator settings, explained in “Configuring the Validator” on page 44.

Differences Between T8000 and T6000 Models

Note that the ODV is supported on both these models of printers but there are differences worth noting as they affect how the ODV is installed and operates. These differences should be considered when reading this document as some cases might not apply to both models.

- The T6000 printers are available in 4-inch and 6-inch widths only. There is no 8-inch width model.
- The T6000 cannot support the cutter with ODV.
- The T6000 does not have Tear-Off option under Media Handling.
- The T6000 printers do not have a tear bar with notches.
- The T6000 only reverses and overstrikes forms by 1” maximum (not the entire form). As a result, not all options within *Validator > Control > Validator Action* are available.
- Because of the limited reverse motion on the T6000, the menu *Validator > Control > Label Save* is default to *Enable* to make sure the form is validated before printing the subsequent labels.

Operational Parameters

The design parameters of the validator are as follows:

- The validator can track the performance of up to four horizontal bar codes at one time.
- The validator requires a minimum distance of 1/2 inch or 20 times the minimum element width (x-dimension), whichever is greater, between bar codes.
- The validator recognizes the following linear, picket fence bar codes: Codabar, Code 39, Code 93, Code 128, Interleaved 2 of 5, and UPC/EAN.
- The validator can also evaluate PDF 417 bar codes. For PDF 417 Limited, the validator works best with security level 5 or higher, using the current default printer settings for Defects Percentage, Percent Decode, and Decodeability. For lower security levels, lower the Defects Percentage to 5% to enable checking for bar code damage.
- Stacked, 2D, and vertical (ladder) bar codes are not supported.
- Bar codes must have a minimum x-dimension of 10 mil (0.010 inch) to be recognized by the full width of the scanning beam. The validator can recognize bar x-dimension as narrow as 6.6 mil (0.0066 inch)

for 300 dpi printers, and 10 mil (0.010 inch) for 203 dpi printers. The validator cannot recognize x-dimensions smaller than 6.6 mil (0.0066 inch) or larger than 40 mil (0.040 inch).

Refer to Table 1 for the minimum x-dimension requirements for each printer size of a 300 dpi printer.

Table 1: Minimum X-Dimension and Beam Width for a 300 dpi Printer

Printer Size	Beam Width	Minimum X-Dimension
4 inch	4.5 inches	6.6 mil
6 inch	6.5 inches	10 mil
8 inch	8.5 inches	13 mil

Note: 8-inch width is available for T8000 only.

Tools and Materials Needed

- Administrator's Manual for your printer model
- Static wrist strap*
- 2.5 mm hex key* (T8000 printers only)
- #2 Phillips Screwdriver
- Flat blade screwdriver (small)
- Diagonal cutters

Parts List

- 3 mm hex key
- Validator and mounting screws
- Validator bracket, mounting screws, and skew adjustment screw
- Cable ties, black
- Bar code calibration card
- Ferrite*
- Cable assembly*
- Wire saddle*
- Split Grommet*
- ODV Interface PCBA

Safety Notices

The validator is a Class 2 laser product. The following notices apply at all times when the printer is powered on and the validator is active:

WARNING Class 2 laser light. Do not stare into the laser beam or a reflected image of the laser beam.

WARNING Using controls, making adjustments, or performing procedures other than those specified herein may result in hazardous radiation exposure.

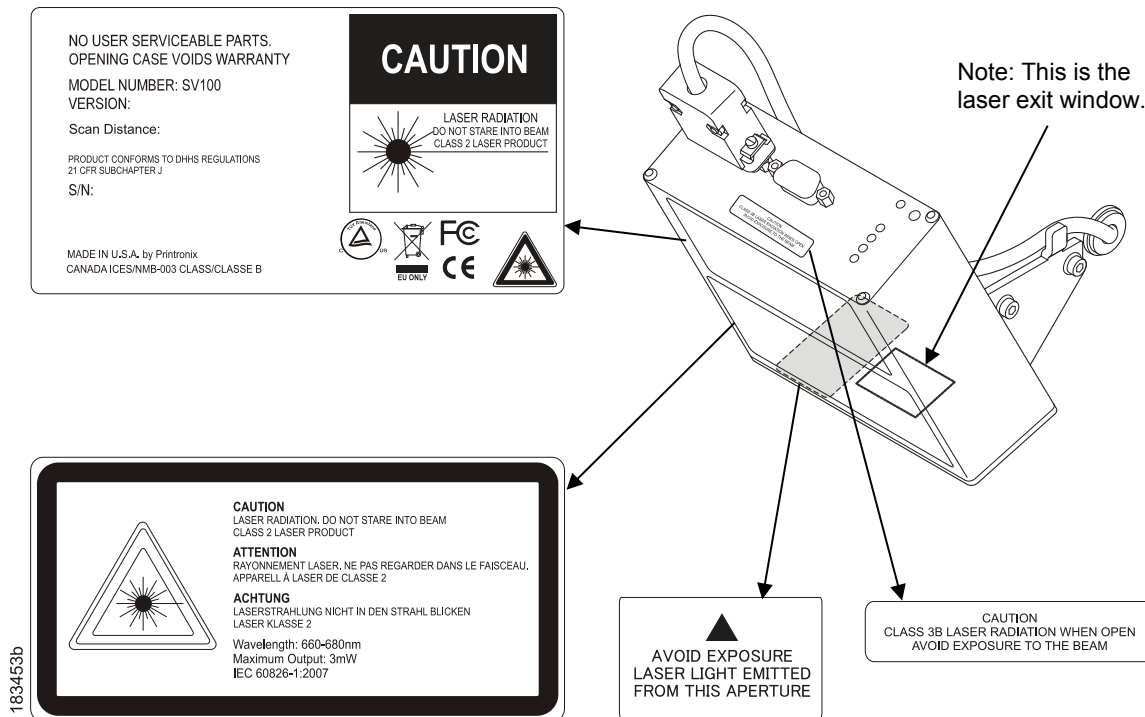

Figure 1 Safety Warnings

T6000 Installation and Removal

Prepare the Printer

1. Set the printer power switch to O (Off).

WARNING Always unplug the printer power cord from the printer or power outlet before doing any installation procedure. Failure to remove power could result in injury to you and damage the equipment. You will be instructed when to apply power.

2. Unplug the printer power cord from the printer or the AC power source.

Factory Installation

If your printer has a factory installed validator, the ferrite, cable, wire saddle, and grommet, have already been installed. Go to “Install the Validator” on page 18.

Field Installation

If you are doing a field installation, you must install the ferrite, cable, wire saddle, and grommet. Go to “Remove the Side Cover” on page 15.

Remove the Side Cover

1. Open the media cover and remove two screws on the inside of the printer as shown in Figure 2.
2. Remove two screws securing the side cover at the back of the printer frame.
3. From the back of the printer lift and tilt up the side cover until the tabs along the lower edge disengage from the slots in the printer base frame.

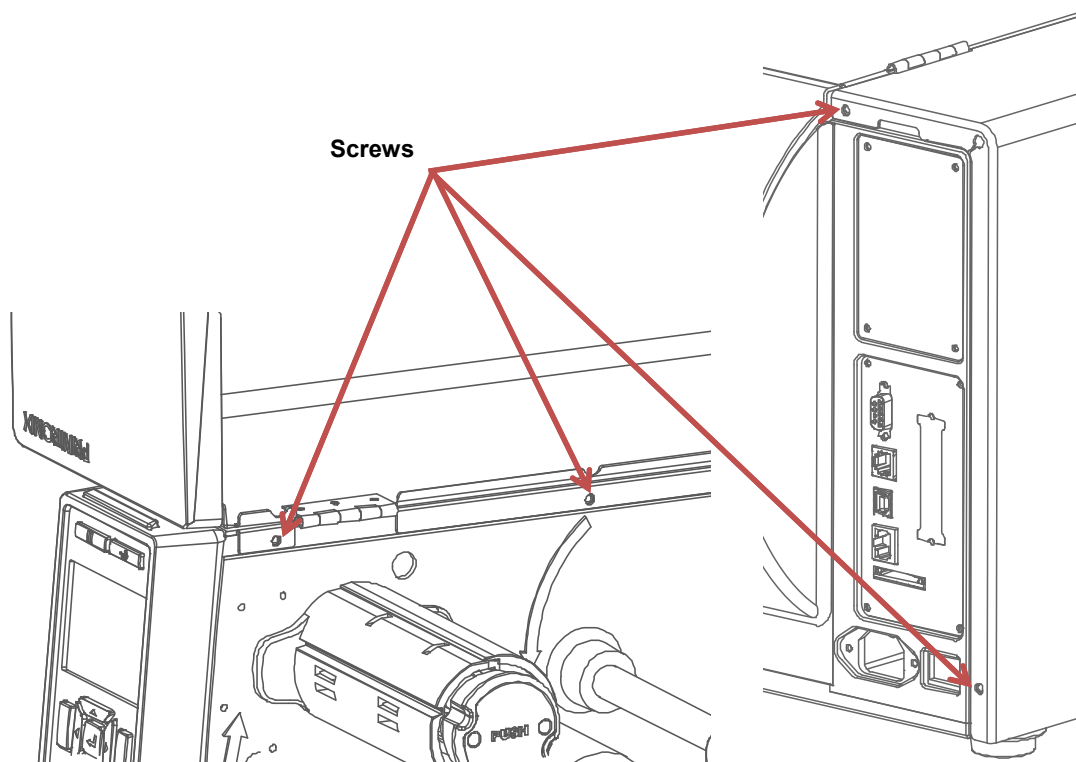

Figure 2 Removing Side Cover (T6)

Routing the Power/Data Cable

CAUTION To prevent electrostatic damage to electronic components, always wear a properly grounded static wrist strap when you handle circuit boards.

1. Put on a static wrist strap and ground it to an unpainted part of the printer frame. Touch the frame with the hand wearing the wrist strap.
2. Raise the media cover and remove the plastic plug from the frame opening.
3. Gently press the small wires of the P10 connector end of the power/data cable against the connector and route the connector through the frame opening.
4. On the media side of the printer, slide the split grommet onto the power/data cable and insert it into the frame opening.

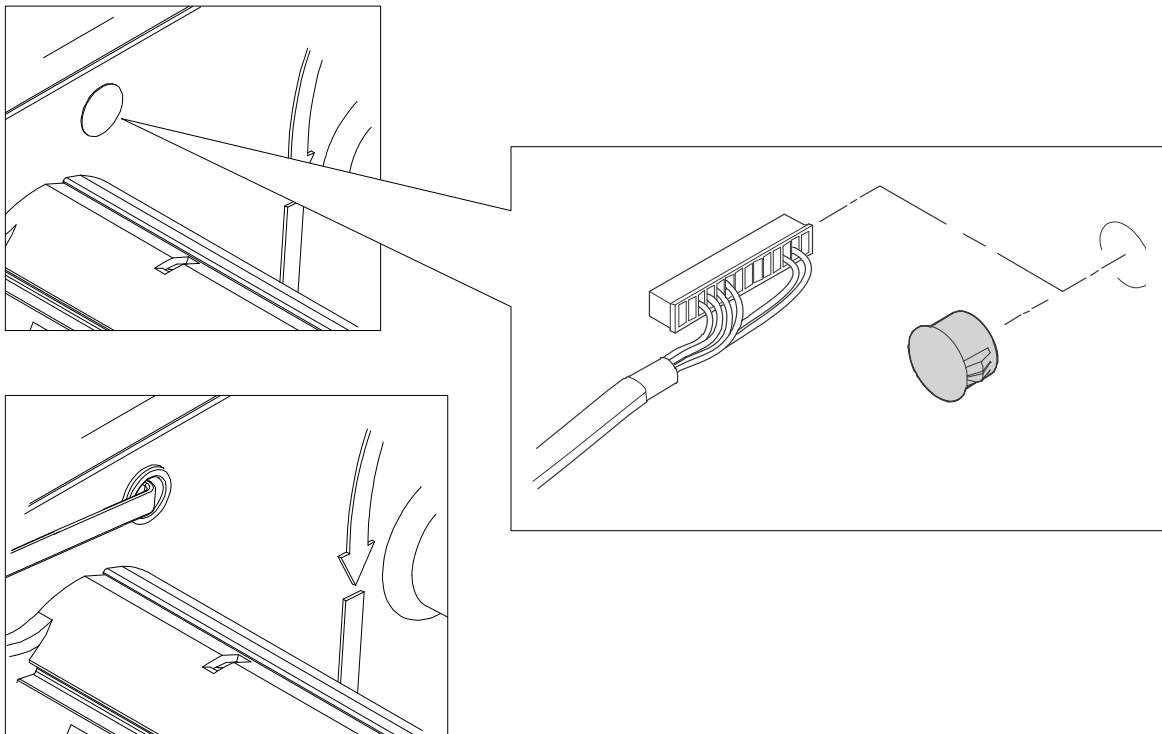

Figure 3 Routing the Power/Data Cable (T6)

5. Inspect the power/data cable to ensure approximately 17 inches of cable is exposed from the split grommet to the back of the DB15 connector that will plug into the validator.

NOTE: You will plug the power/data cable into the validator later.

6. On the electronics side of the printer, take the P10 connector of the power/data cable and insert it through the ferrite and wrap the cable around the ferrite twice.
7. Remove the protective liner from the base of the Nylon cable clamp and use the exposed adhesive to secure the clamp to the frame next to the frame opening.
8. Secure the ferrite to the Nylon cable clamp as shown in Figure 4 and route the P10 connector and power/data cable down towards the bottom of the controller PCBA.

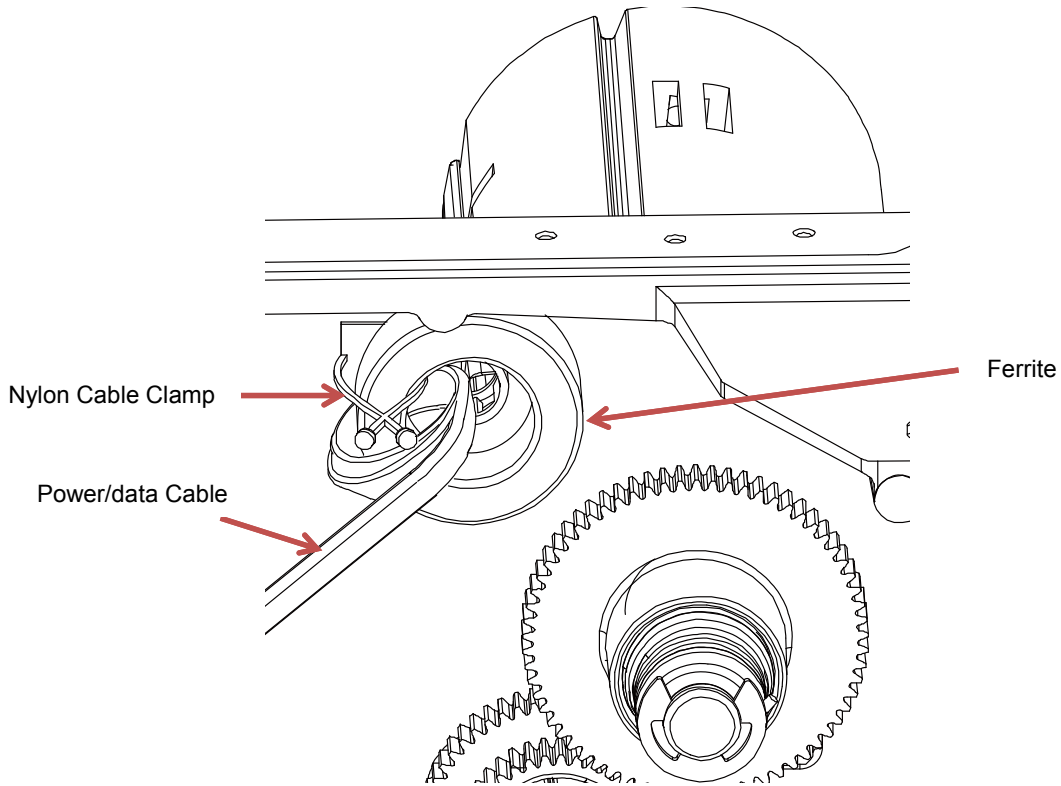

Figure 4 Secure Ferrite to Nylon Cable (T6)

Installing the ODV Interface PCBA

1. Plug the ODV interface PCBA P10 connector into the J10 receptacle on the controller PCBA and then press the large brass pin on the ODV interface PCBA into the guide hole on the controller PCBA.
2. Plug the connector end of the power/data cable into the J10 receptacle on the ODV Interface PCBA as shown in Figure 5.

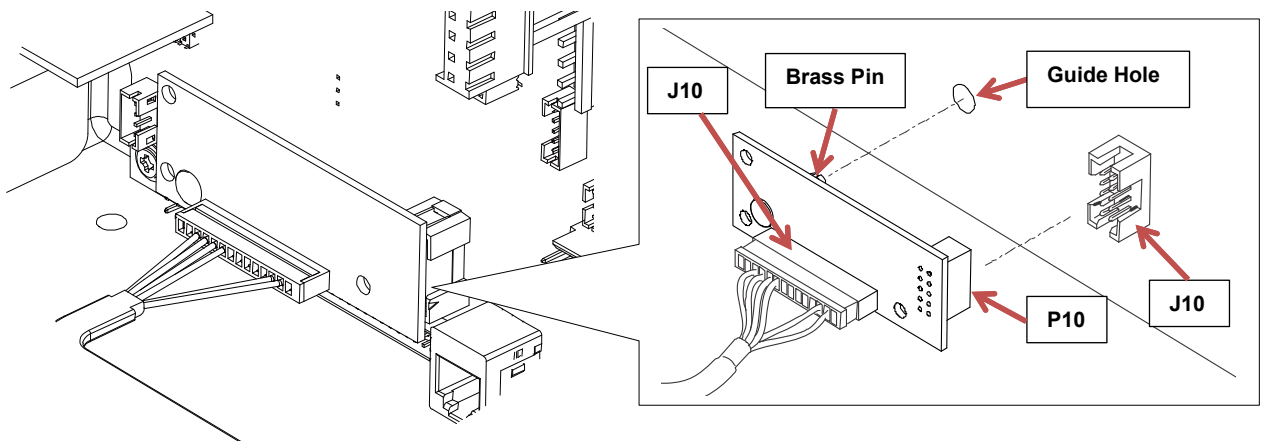

Figure 5 Installing ODV interface PCBA (T6)

Install the Validator

1. Use the two 6-32 Phillips head screws (provided) and attach the validator to the bracket.
2. Use the appropriate holes on the bracket, depending on the model width (4" or 6").
3. Apply even pressure to the side of the validator as you tighten the screws on the bracket.
4. Make sure the validator is firmly seated against both screws to insure proper beam alignment.

NOTE: Figure 6 below shows validator mounted in 4" model position.

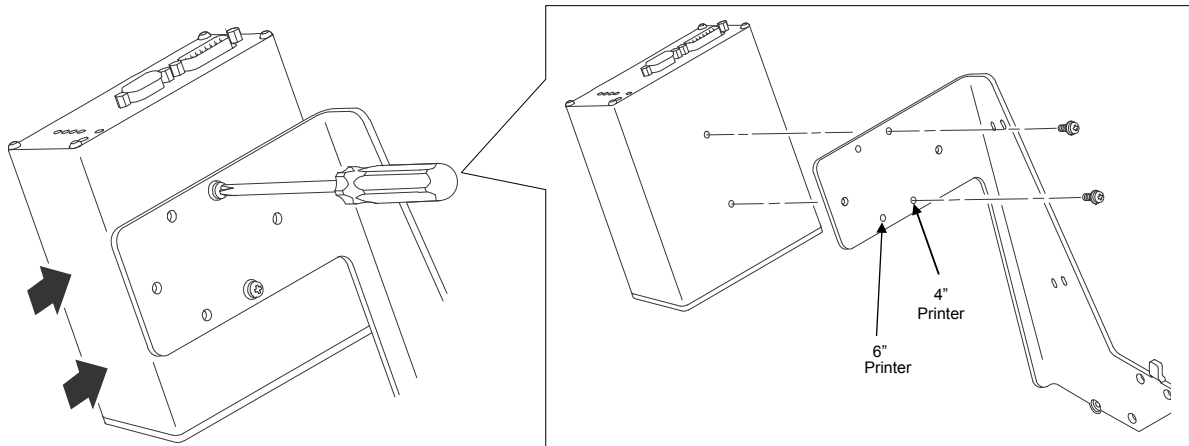

Figure 6 Attach Validator to the Bracket (T6)

5. Face the front of the printer while installing the validator/ bracket unit.
6. Using four M4x10mm screws (provided), attach the validator/bracket unit to the printer frame.
7. Tighten the four screws finger tight. You will adjust the validator/bracket unit in a later step using the 3mm hex key (provided).
8. Refer to Figure 7.

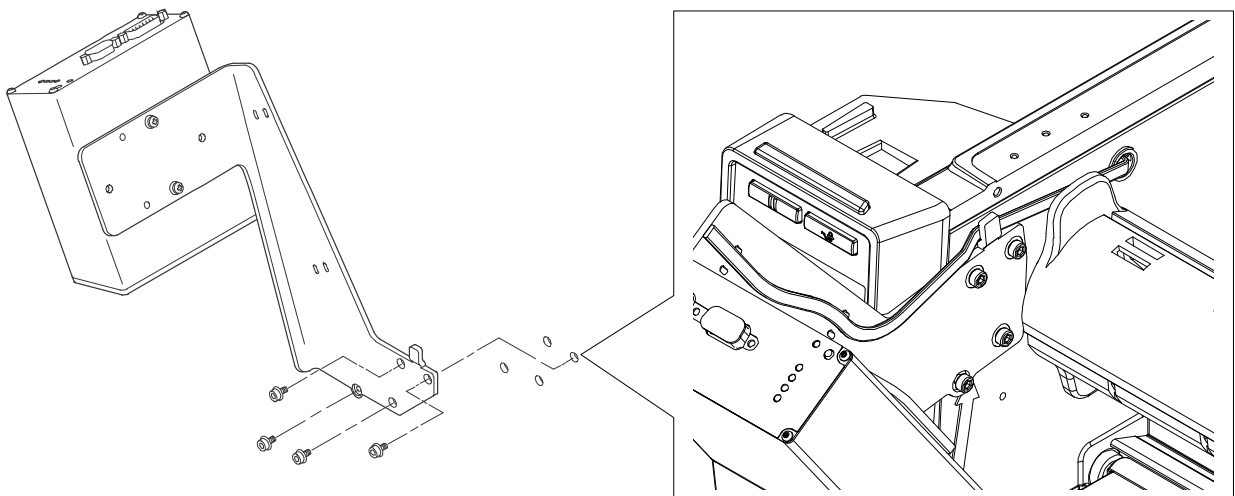

Figure 7 Attach Validator to the Bracket (T6)

Attach the Power/Data Cable

1. Plug the DB15 end of the power/data cable into the validator connector and secure it using the captive screws on each side of the plug.
2. Route the power/data cable along the inside of the bracket, as shown on next page.
3. Route a tie wrap from the inside of the bracket through the first upper slot as shown on next page, keeping the power/data cable underneath the tie wrap.
4. Route the tie wrap back through the second upper slot and underneath the power/data cable and then through the tie wrap head, as shown in Detail.
5. Pull the tie wrap just enough to hold the cable in place, but do not over tighten it.
6. Repeat step 3 through step 5 using the lower pair of slots.
7. Route the power/data cable behind the bracket tab as shown on next page.

NOTE: If necessary, loosen the bracket mounting screws enough to slip the power/data cable behind the bracket tab, then retighten the bracket mounting screws.

8. Gently pull the power/data cable to minimize the slack along and behind the bracket. Push any excess slack through the grommet.
9. Once the power/data cable is properly positioned, pull the tie wraps snug against the cable and bracket and cut off the excess.

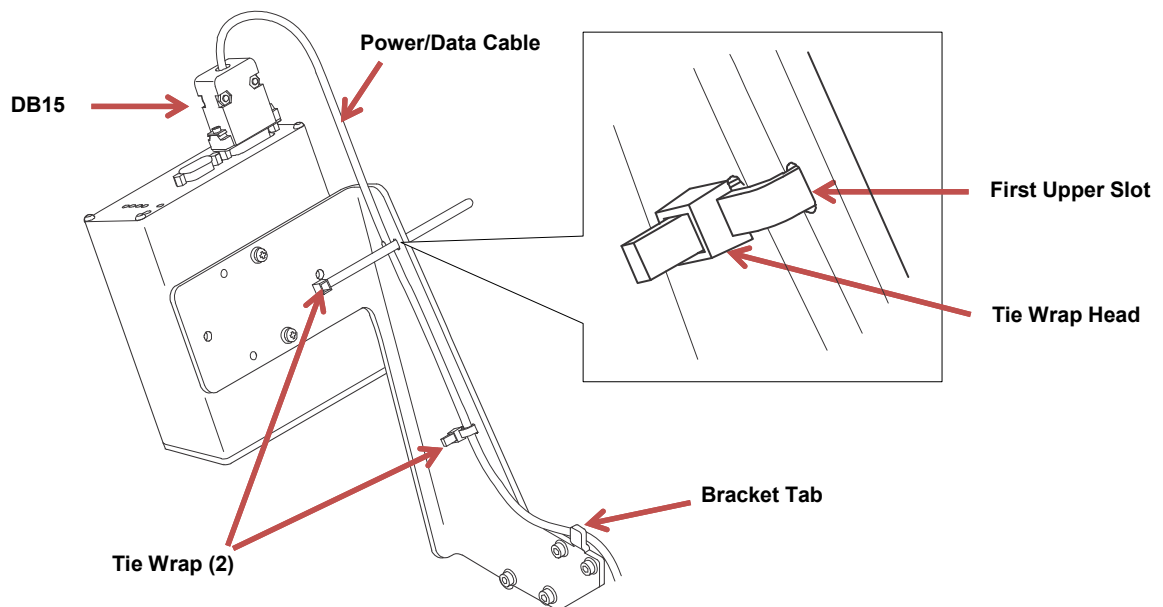

Figure 8 Attach Power/Data Cable (T6)

To Restore the Printer to Operation, refer to the section “Restore the Printer to Operation” on page 34 followed by the section “Enable the Validator” on page 34.

To Adjust the Scanning Beam, refer to the section “Adjust the Scanning Beam” on page 35.

T8000 Installation and Removal

This section describes how to install the validator. To remove the validator, reverse the steps of this procedure.

Prepare the Printer

3. Set the printer power switch to O (Off).

WARNING Always unplug the printer power cord from the printer or power outlet before doing any installation procedure. Failure to remove power could result in injury to you and damage the equipment. You will be instructed when to apply power.

4. Unplug the printer power cord from the printer or the AC power source.

Factory Installation

If your printer has a factory installed validator, the ferrite, cable, wire saddle, and grommet, have already been installed. Go to "Install the Validator" on page 29.

Field Installation

If you are doing a field installation, you must install the ferrite, cable, wire saddle, and grommet. Go to "Install the Ferrite" on page 20.

Install the Ferrite

1. Loosen the three captive screws securing the top of the frame side cover. ()
2. Tilt the frame side cover back from the top and lift it until the tabs along the lower edge disengage from the slots in the printer frame.

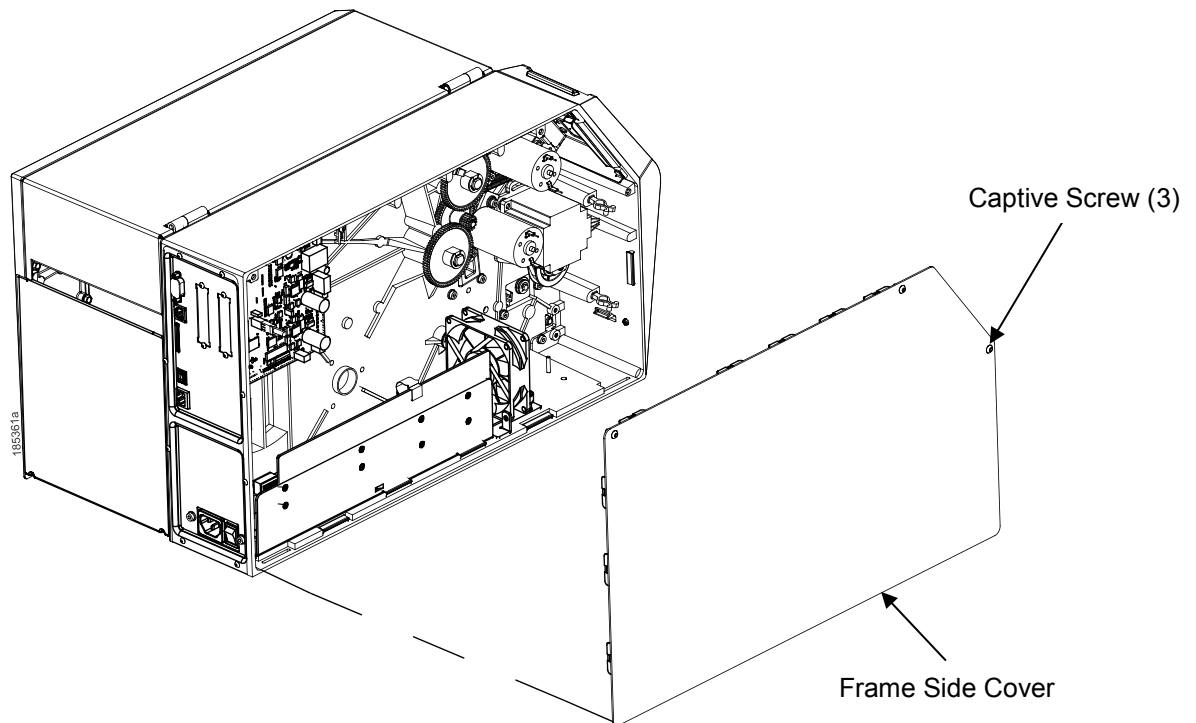

Figure 9 Removing the Frame Side Cover (T8)

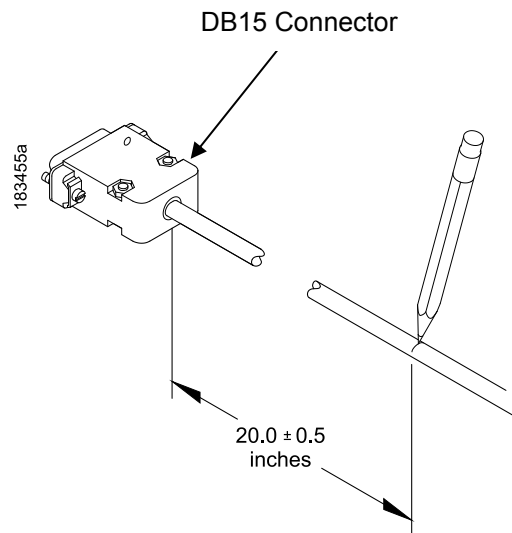

Figure 10 Locating the Ferrite Position on the Power/Data Cable (T8)

3. Stretch the Power/Data cable out straight on a flat surface.
4. Measure back 20.0 ± 0.5 inches from DB15 connector and mark the cable with a pencil line (Figure 10).

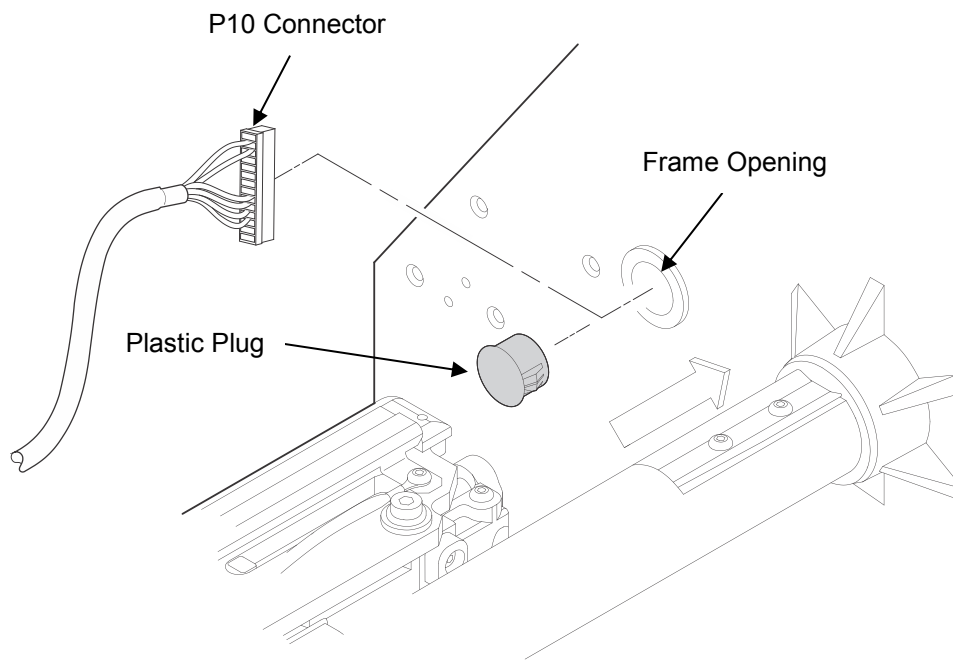

Figure 11 Routing the Power/Data Cable (T8)

CAUTION To prevent electrostatic damage to electronic components, always wear a properly grounded static wrist strap when you handle circuit boards.

5. Put on a static wrist strap and ground it to an unpainted part of the printer frame. Touch the frame with the hand wearing the wrist strap.
6. Raise the media cover and remove the plastic plug from the frame opening.
7. Gently press the small wires of the P10 connector end of the power/data cable against the connector and route the connector through the frame opening (Figure 11).

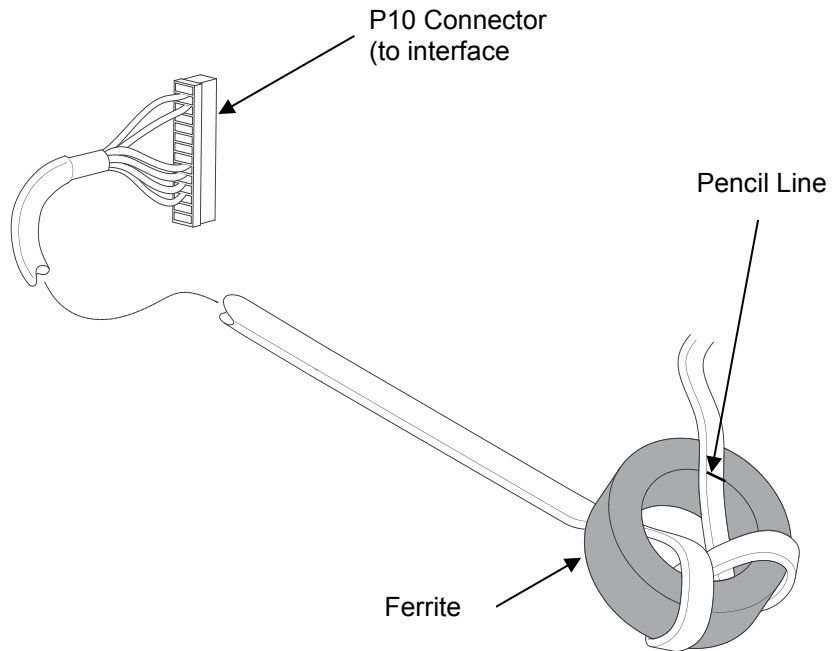

Figure 12 Wrapping the Power/Data Cable Around the Ferrite (T8)

8. Using the P10 connector end of the power/data cable, insert the cable through the ferrite (Figure 12).
9. Wrap the power/data cable around the ferrite twice.
10. Adjust the position of the ferrite so that the length from the ferrite to the DB15 connector is 20 ± 0.5 inches.

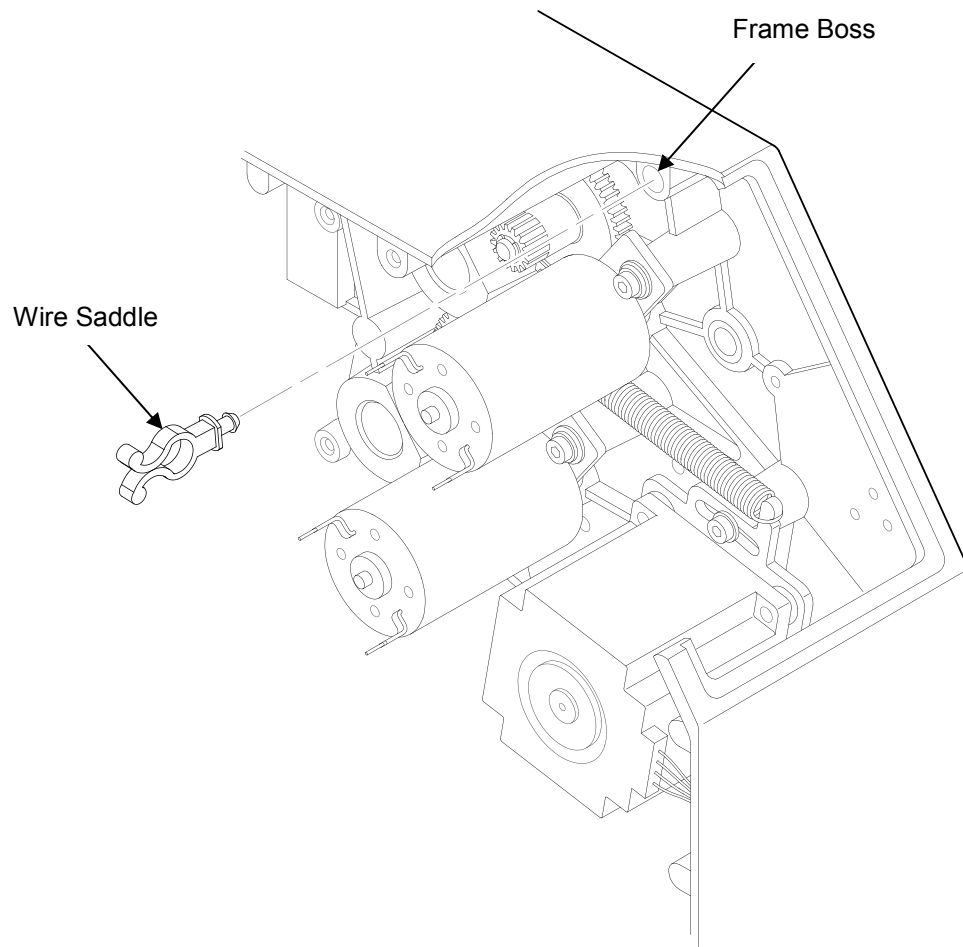

Figure 13 Inserting the Wire Saddle into the Frame Boss (T8)

11. Insert the wire saddle into the frame boss (Figure 13).

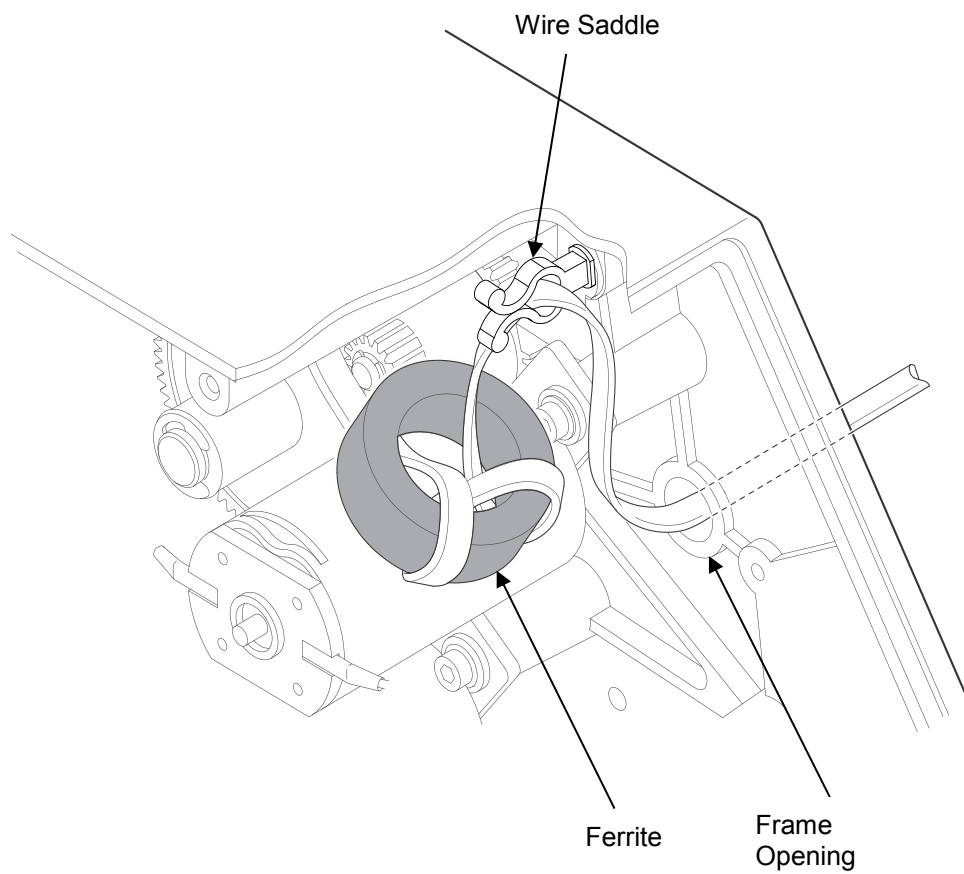

Figure 14 Routing the Power/Data Cable from the Hole in the Frame Wall (T8)

12. Route the power/data cable through the wire saddle.

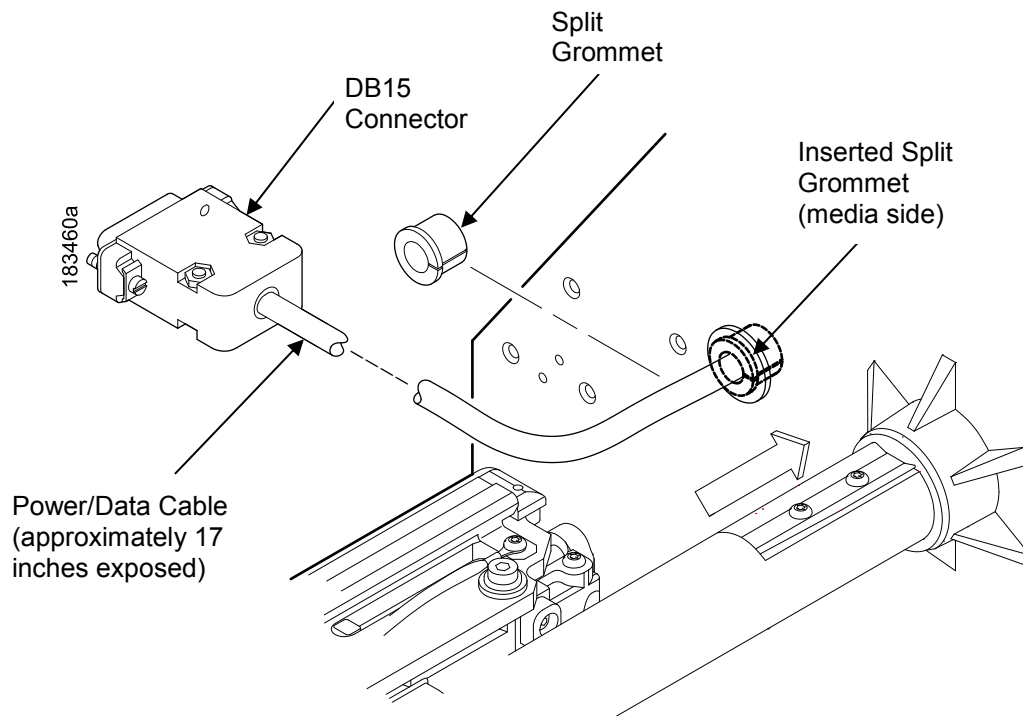

Figure 15 Adding the Grommet to the Power/Data Cable (T8)

13. On the media side of the printer, slide the split grommet onto the power/data cable and insert it into the frame opening. (Figure 15)
14. Inspect the power/data cable to ensure approximately 17 inches of cable is exposed from the grommet to connect it to the validator.

NOTE: You will plug the power/data cable into the validator later.

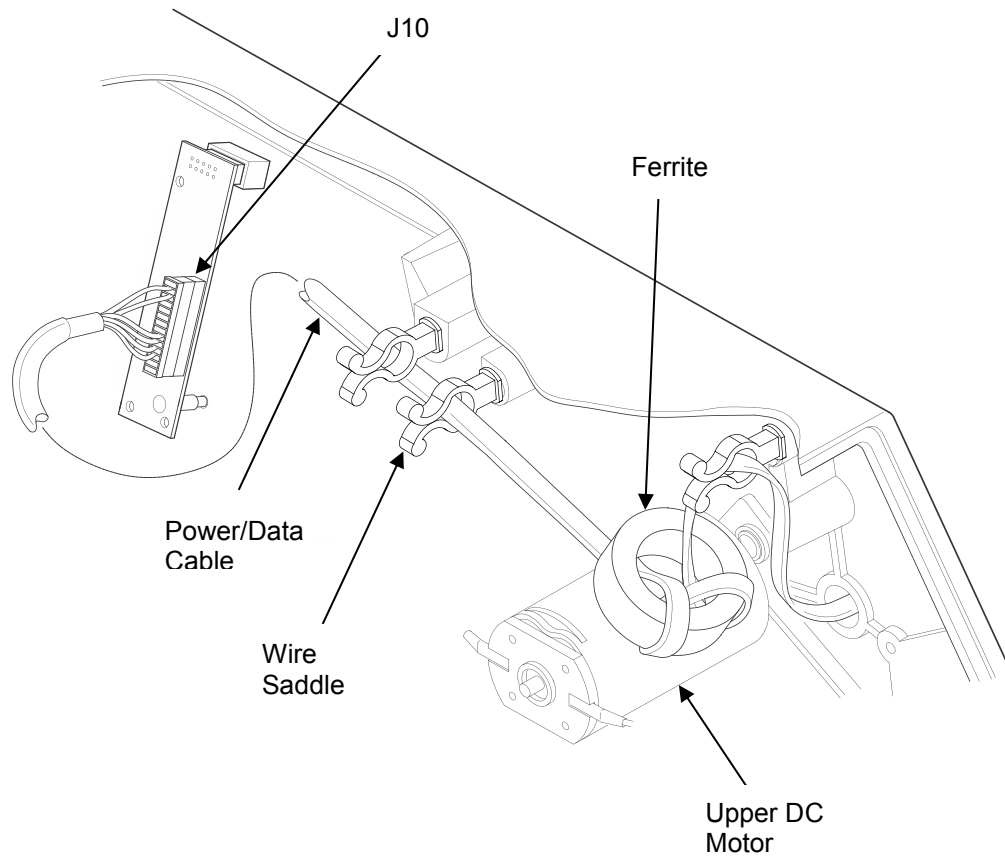

Figure 16 Position the Ferrite (T8)

On the electronics side of the printer, position the ferrite on top of the upper DC motor. (

15. Figure 16)

Route the power/data cable through the wire saddle as shown in

16. Figure 16.

17. Plug the P10 connector end of the power/data cable into the J10 receptacle on the ODV Interface board. See Figure 17 on page 28.

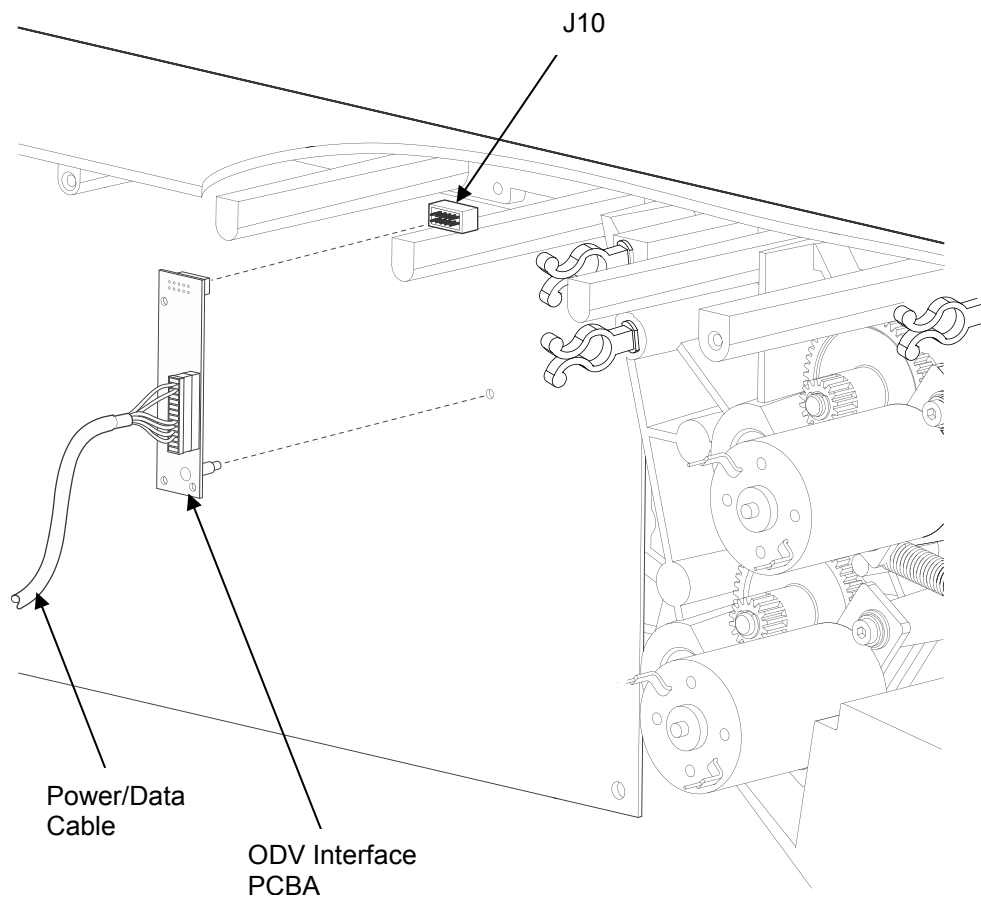

Figure 17 Connecting the ODV PBCA and Controller (T8)

Install the Validator

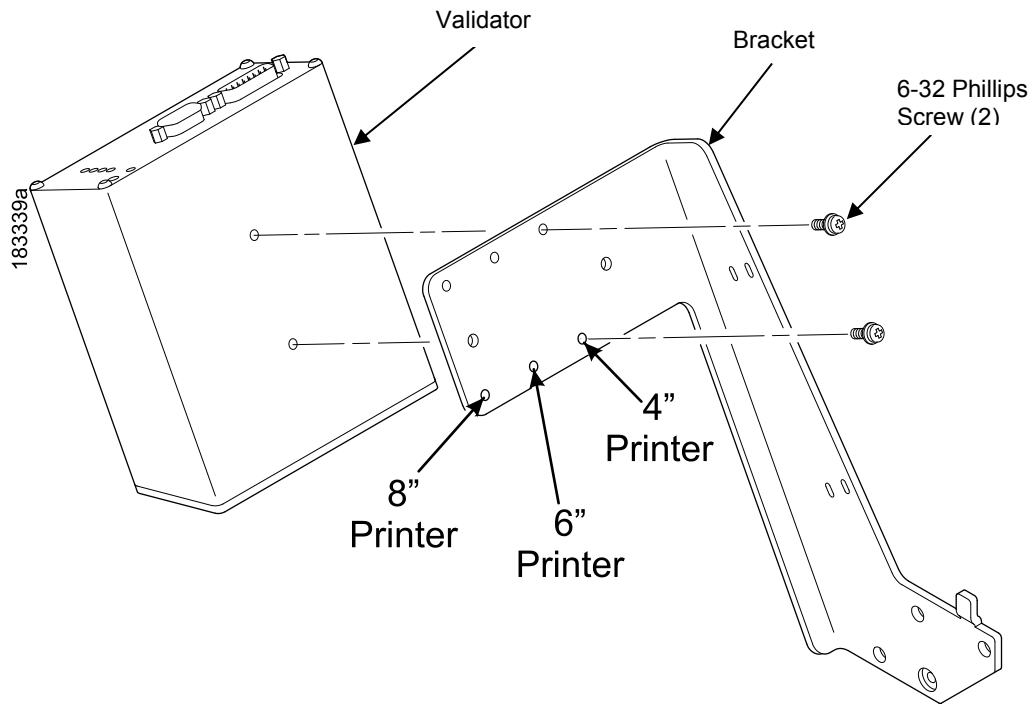

Figure 18 Attaching the Validator to the Bracket (T8)

1. Using two 6-32 Phillips head screws, attach the validator to the bracket as shown in Figure 18.
2. Use the appropriate holes on the bracket, depending on the media width.

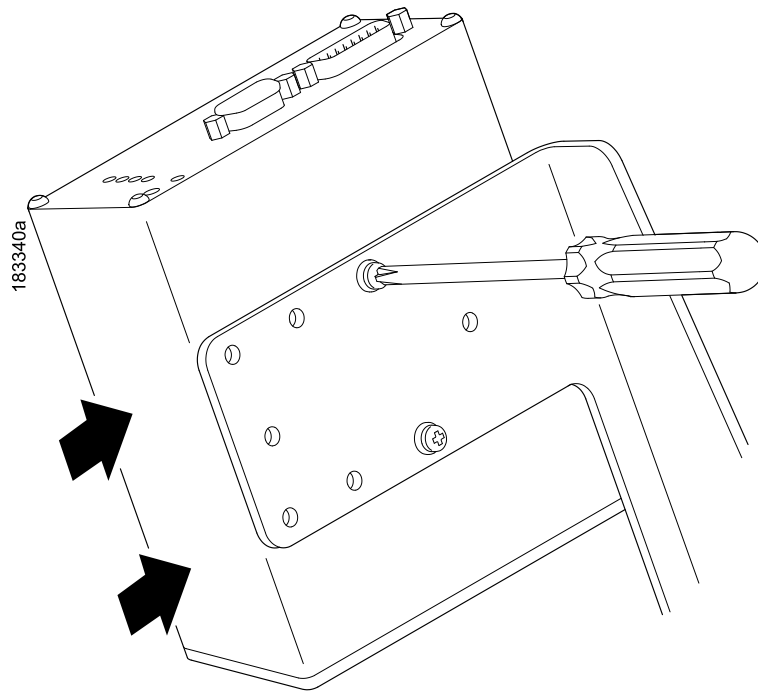

Figure 19 Positioning the Validator on the Bracket (T8)

1. Apply even pressure to the side of the validator as you tighten the screws on the bracket as shown in Figure 19.
2. Make sure the validator is firmly seated against both screws to insure proper beam alignment.

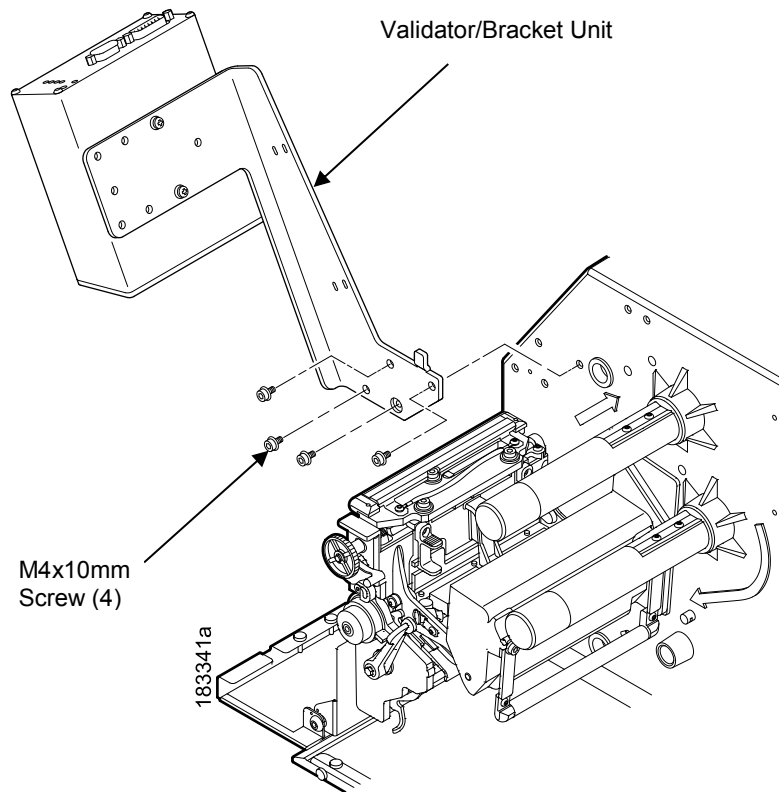

Figure 20 Attaching the Validator/Bracket Unit to the Printer (T8)

3. Face the front of the printer while installing the validator/ bracket unit.
4. Using four M4x10mm screws (provided), attach the validator/bracket unit to the printer frame as shown in Figure 20.
5. Tighten the four screws finger tight. You will adjust the validator/bracket unit in a later step using the 3mm hex key (provided).

Attach the Power/Data Cable

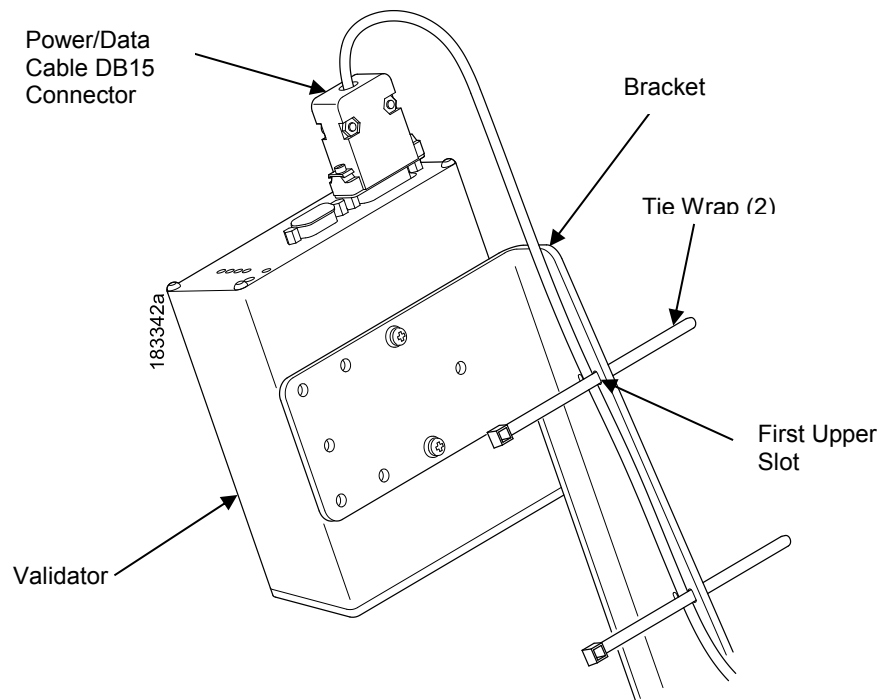

Figure 21 Attaching the Power/Data Cable (T8)

1. Plug the DB15 connector end of the power/data cable into the validator. Use a small flat blade screwdriver to tighten the screws located on each side of the connector.
2. Route the power/data cable along the inside of the bracket, as shown in Figure 21.
3. Route a tie wrap from the inside of the bracket through the first upper slot as shown in Figure 21, keeping the power/data cable underneath the tie wrap.

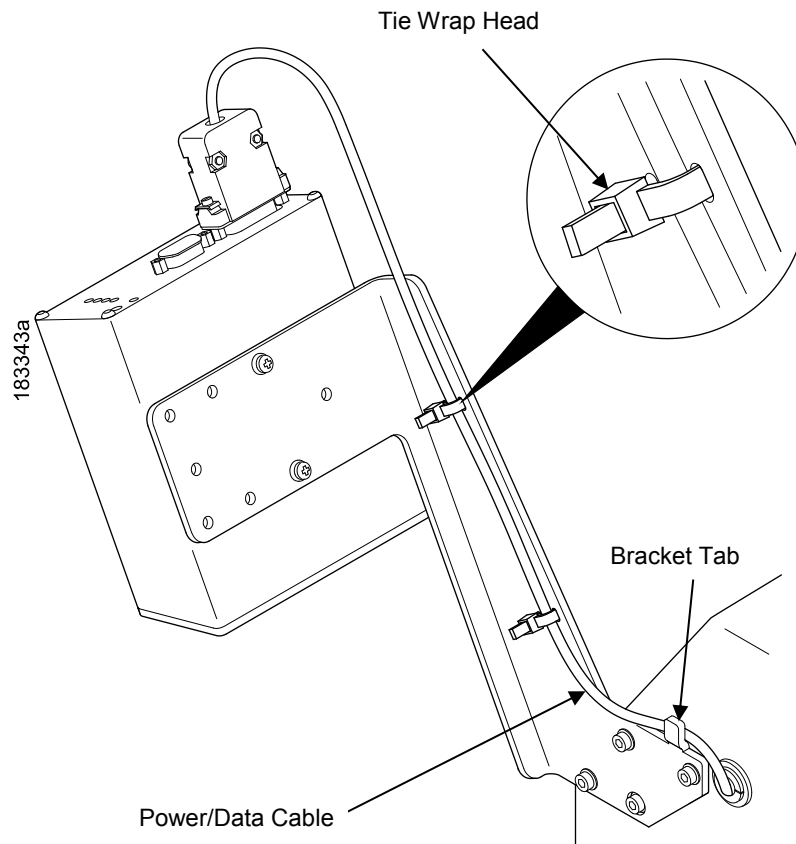

Figure 22 Securing the Power/Data Cable (T8)

4. Route the tie wrap back through the second upper slot and underneath the power/data cable and then through the tie wrap head, as shown in Detail A of Figure 22.
5. Pull the tie wrap just enough to hold the cable in place, but do not over tighten it.
6. Repeat step 3 through step 5 using the lower pair of slots.
7. Route the power/data cable behind the bracket tab as shown in Figure 22.

NOTE: If necessary, loosen the bracket mounting screws enough to slip the power/data cable behind the bracket tab, then retighten the bracket mounting screws.

8. Gently pull the power/data cable to minimize the slack along and behind the bracket. Push any excess slack through the grommet.
9. Once the power/data cable is properly positioned, pull the tie wraps snug against the cable and bracket and cut off the excess using a diagonal cutter.

Restore the Printer to Operation

1. Lower the media cover.
2. Engage the tabs on the bottom of the frame side cover in the slots in the printer frame.
3. Rotate the cover into position.
4. Tighten the hardware, see Figure 2 (Page 15) for T6000 or Figure 9 (Page 20) for T8000.
5. Plug the AC power cord into the printer and the power source.
6. Set the printer power switch to | (On).

Enable the Validator

IMPORTANT If you make any changes to the default configuration menu items, you will be prompted to save the configuration when you attempt to put the printer online. See the *Administrator's Manual* for more information.

Software can automatically detect an installed validator when the printer is powered up. The state of the Validator can be observed from the ONLINE screen as shown in Figure 23 below:



- The ONLINE screen will show the “enabled” validator symbol  under the model number when the validator is installed AND enabled via the menu Validator > Control > Validator Active.
- The ONLINE screen will show the “disabled” validator symbol  under the model number when the validator is installed and disabled via the menu Validator > Control > Validator Active.
- If the Validator is not installed, then no validator symbol will be present on the ONLINE screen. Furthermore, the full color Validator icon shown in the Settings section in Figure 23 is replaced with a greyed out version which the user cannot select.

Figure 23 Validator Icon



Once the Validator is installed, the Validator section under Settings can be selected and the Validator configured. However, it may not be enabled by default:

- If the printer is powered up with the menu *Configs > Control > Power-Up Config* set to Factory, the *Validator > Control > Validator Active* will be set to “Enable” automatically.
- If the printer is powered up with *Configs > Control > Power-Up Config* to something other than Factory, the *Validator > Control > Validator Active* is set to “Disable”.

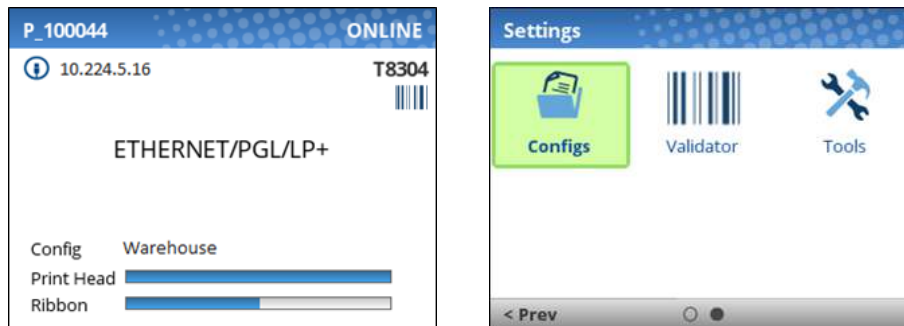
To enable the Validator, change the menu *Validator > Control > Validator Active* to “Enable” and save the configuration as described in the *Administrator's Manual*.

IMPORTANT Do not enable or disable the validator with data in the buffer. See “Resetting Validator Data” on page 45.

Adjust the Scanning Beam

IMPORTANT Make sure the printer is on and the scanning beam is on. If the beam is off, press the RESET button for less than 2 seconds to turn on the beam.

Continuous, Tear-Off, and Tear-Off Strip

When the validator is first installed, the scanning beam may need to be aligned with the two notches on the sides of the tear bar, as shown in Detail A of Figure 24. When the scanning beam is properly aligned it will line up with the two notches.

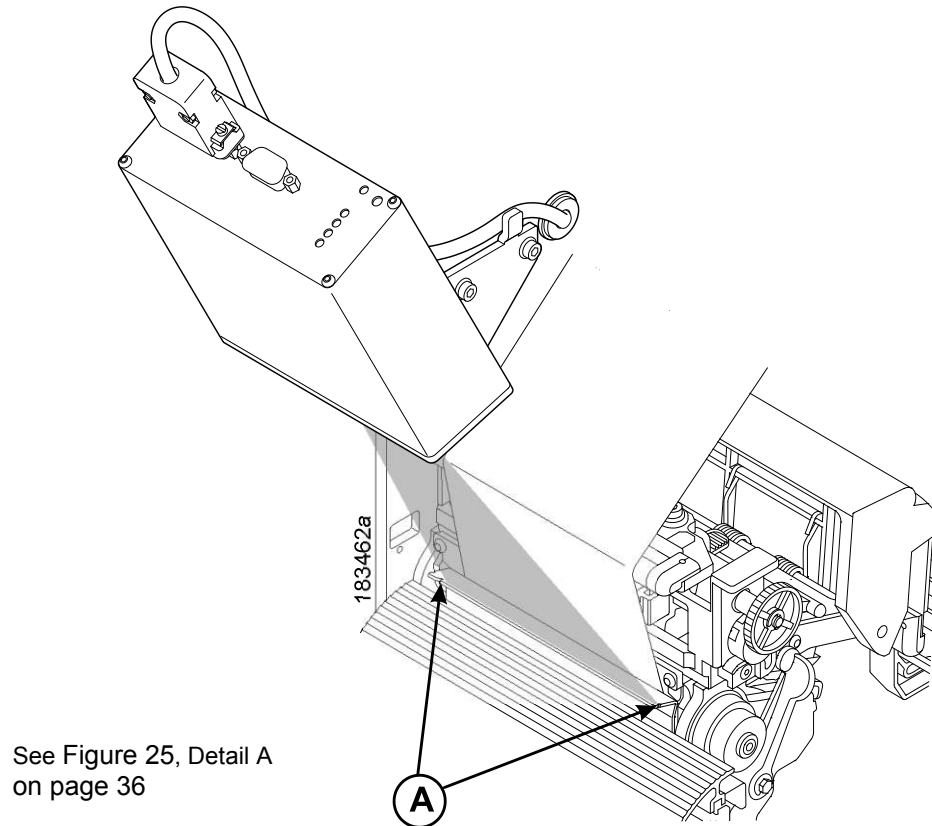

See Figure 25, Detail A
on page 36

Figure 24 Aligning the Scanning Beam: Continuous, Tear-Off, and Tear-Off Strip Media Handling Modes (where applicable)

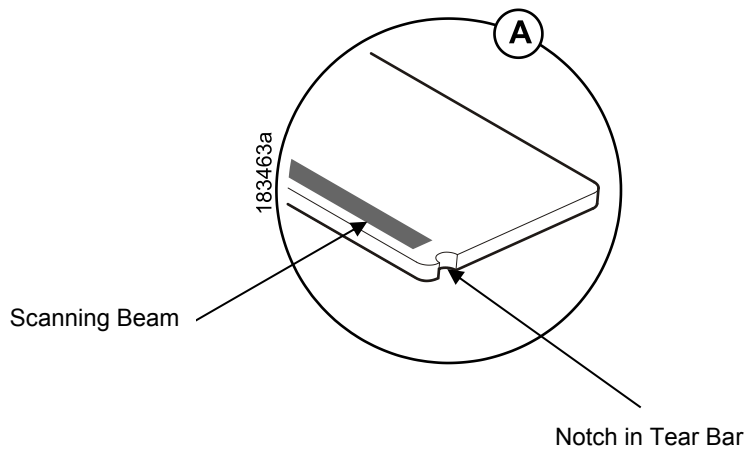

Figure 25 Scanning Beam Location

Peel-Off Media Handling Mode

If your printer is configured for Peel-Off Media Handling mode (use of optional internal rewinder), you may need to align the beam further behind the notches (0.14 to 0.20 inches [3.56 mm to 5.07 mm] from the front edge of the tear bar) so that the peeled label remains on the tear bar and the trailing edge of the last bar code can still pass completely under the scanning beam. See Figure 26

Aligning the scanning beam to any position other than the notches on the tear bar should only be done if the last printed bar code image does not clear the beam when the label is at the peel-off position after printing. In addition, the distance the beam moves back from the tear bar edge must correspond to a distance from the leading edge of the label that does not have bar code printing. For example, aligning the beam 0.16 inches from the front edge of the tear bar requires that 0.16 inches of the leading edge of the label must not have bar code images.

IMPORTANT T6000 printers **DO NOT** have a tear bar with notches.

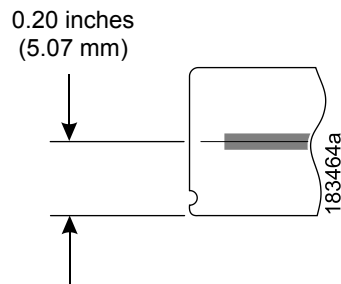
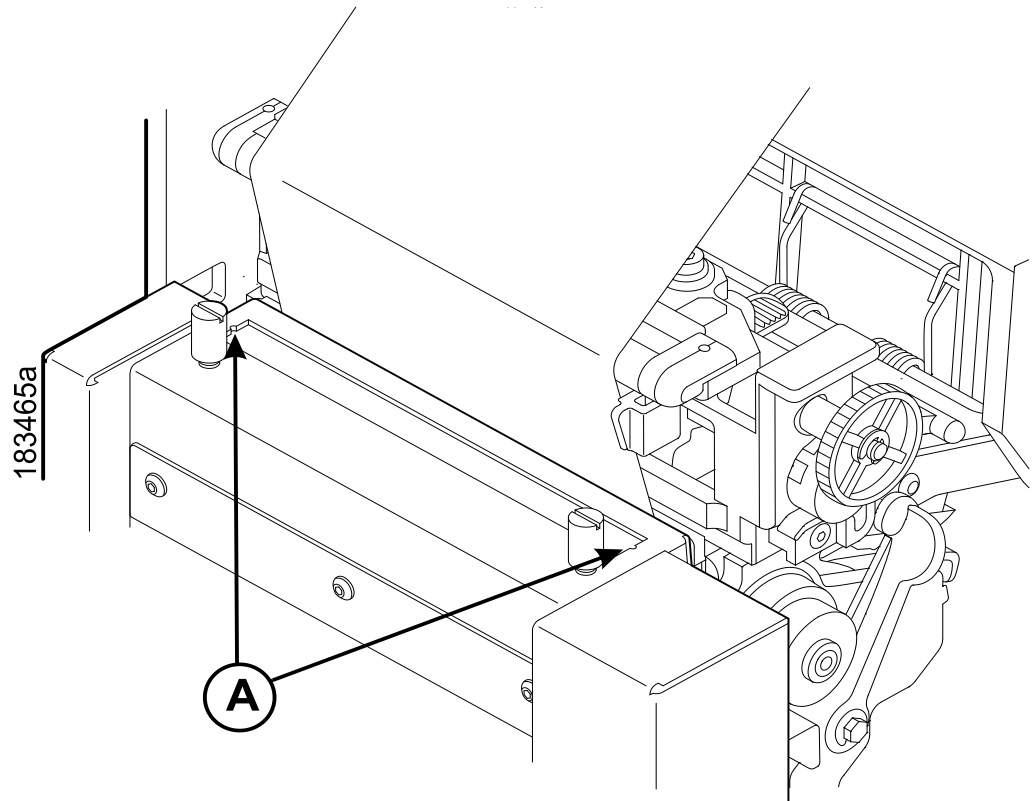

Figure 26 Aligning the Scanning Beam: Peel-Off Media Handling Mode Only

Cut Media Handling Mode (T8000 only)

IMPORTANT T6000 printers DO NOT support the Validator when a Cutter option is installed.

If your printer has a cutter installed and is configured for Cut Media Handling Mode, align the beam at the notches at each side of the opening on the upper enclosure, as shown in Detail A of Figure 27.



See Figure 28,
Detail A on
page 38

Figure 27 Aligning the Scanning Beam: Cutter Installed

IMPORTANT The beam must make direct contact with the media, not the inside metal part of the cutter. See Figure 29 for instructions on how to adjust the vertical position of the beam.

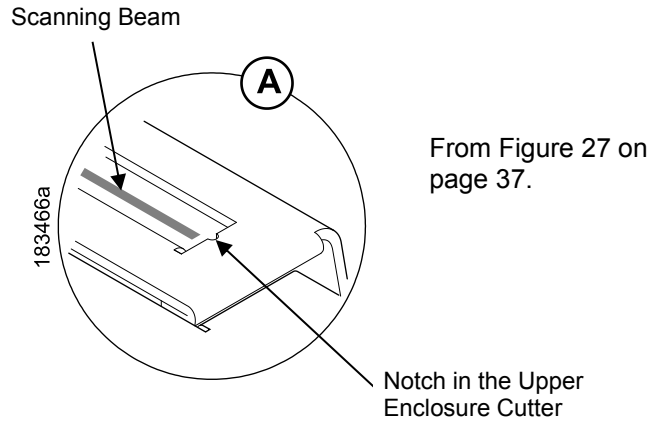

Figure 28 Scanning Beam Location: Cutter Installed

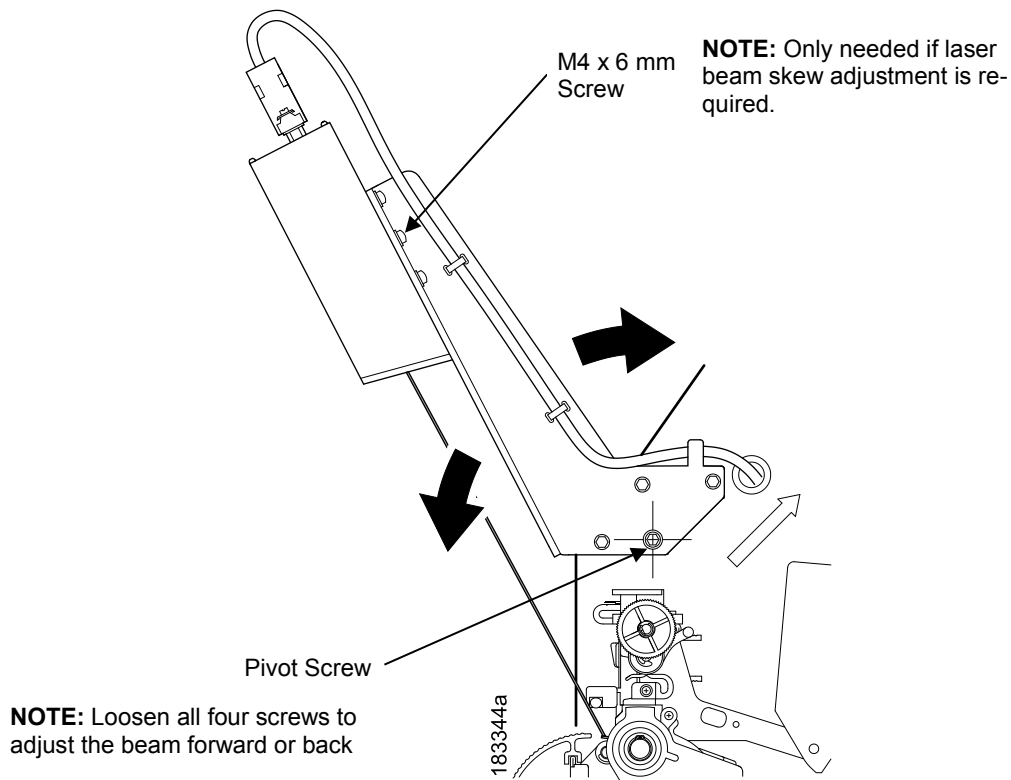

Figure 29 Scanning Beam Adjustment Screws

Figure 29 shows the screws used to adjust the position of the scanning beam. The positions of the screws assume that you are in front of the validator unit and facing the printer. The following instructions and illustrations show how to adjust the validator according to how the beam appears.

1. Power the printer on and make sure the scanning beam is on. If the beam is off, press the RESET button for less than 2 seconds to turn on the scanning beam.
2. Use the hex key provided to adjust the screws.
3. Loosen the four screws so the validator/bracket unit can be rotated about the pivot screw.

Scanning Beam Vertical Alignment



Correct vertical alignment of the scanning beam. The beam lines up with the end notches and is parallel to the long edge of the tear bar.



Raise the validator/bracket unit to move the scanning beam forward. Once the beam is correctly aligned with the end notches, tighten the four screws.

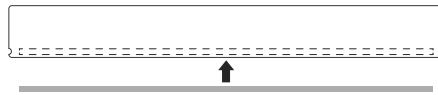

Lower the validator/bracket unit to move the scanning beam back. Once the beam is correctly aligned with the end notches, tighten the four screws.

Scanning Beam Skew Adjustment

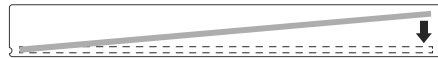

Install the M4 x 6 mm screw in the right threaded (outboard) hole and use the 3 mm allen wrench to gradually turn the screw clockwise until the beam is parallel.

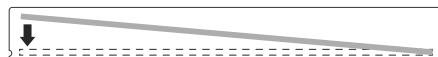

Install the M4 x 6 mm screw in the left threaded hole and use the 3 mm allen wrench to gradually turn the screw clockwise until the beam is parallel.

Shifting the Scanning Beam

The menu option *Validator > Scanner > Beam Shift* enables you to shift the scanning beam horizontally to the left or right. The left edge of the beam should be approximately 0.25 inches (6.35 mm) past the left edge of the tear bar or the upper enclosure of a cutter assembly. See the section Beam Shift on page 61 for parameter settings and defaults.

Calibration

WARNING Class 2 laser light. Do not stare into the laser beam or a reflected image of the laser beam.

WARNING Using controls, making adjustments, or performing procedures other than those specified herein may result in hazardous radiation exposure.

The validator should be calibrated when it is first installed or when the printer displays Calibration warning. A special calibration bar code card is included with the validator package.

1. Make sure the printer is powered on and OFFLINE (using the PAUSE key), and that the validator power light and scanning beam are on. If the beam is off, press the RESET button for less than 2 seconds to turn on the beam.

NOTE: The Power Save mode powers the validator off. Press any key to restore power and turn on the beam within 21 seconds.

Table 2. RESET Button Settings

Time RESET Button Is Depressed	Result
Less than 2 seconds	Turns on the scanning beam
More than 4 but less than 6 seconds	Validator goes into calibration mode
More than 6 seconds	Resets validator to the last good calibration settings and turns off the scanning beam

2. If the printer has the cutter option (T8000 only), put the cutter in the open (down) position.
3. Remove the calibration bar code card from its protective sleeve and slide the top edge between the printhead and platen and under the scanning beam (Figure 30).

NOTE: Do not unlock the deck lock lever.

4. Make sure the bar code is under the scanning beam.
5. Press and hold the **RESET** button on the validator for 4 to 6 seconds until the READ light illuminates and the CALIBRATION light begins flashing.

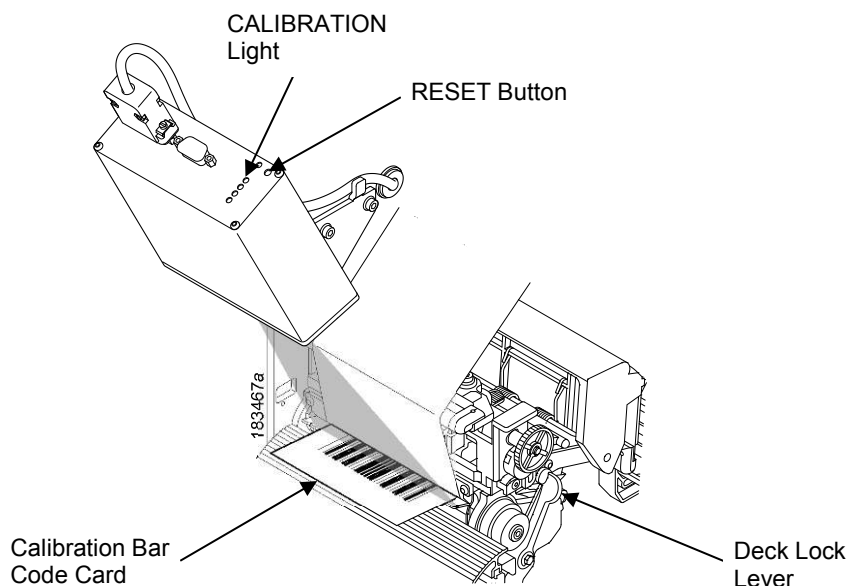

Figure 30 Calibrating the Validator

6. Within a few seconds the CALIBRATION and READ light will turn off. This indicates a successful calibration.

NOTE: If the calibration light is still on or flashing, the calibration has failed. In this case, refer to Table 2 (top of page) to repeat the calibration procedure or to reset the validator settings back to the last good calibration settings.

7. Once you have a successful calibration, remove the calibration bar code card.
8. Power the printer off, wait a few seconds, then power the printer on.

If the calibration was successful, the scanning beam is on and the CALIBRATION light is off. If the calibration was not successful, the scanning beam remains on and the CALIBRATION light stays lit without flashing. Repeat the calibration procedure. If repeated attempts fail, check the room for excessive ambient light, including direct sunlight. You may need to move the printer to a darker area of the room.

NOTE: In some cases the validator can detect and indicate to the printer that calibration is required. See Configuration warning in Table 6 on page 75.

Bar Code Validation Demo Page

The bar code validation demo page allows you to test or demonstrate the validator operation without a host computer. This page contains some text and two good bar code symbologies: one in Code 39, the other in Code 128. (Min. label size 2" W x 1" L)

NOTE: If the menu *Media > Image > Label Length* is set between 0.5 and 1.0 inches, only the Code 128 bar code will print.

If Label Length is less than 0.5 inches or Label Width is less than 2.0 inches, no demo page will print.

To print and validate the bar code validation demo page:

1. Load the factory default configuration. (Refer to the *Administrator's Manual*.)
2. Set *Validator > Control > Validator Active* to "Enable".
3. Set *Sensors > Control > Gap/Mark Sensor* to "Gap".
4. Load media.
5. Using *Sensors > Calibrate > Auto Calibrate* or by selecting  in the Home screen, run Auto Calibrate for proper gap sensing.
6. Edit the menu *Tools > Print Tests > Run Tests*. If the panel is locked, press the UP+DOWN ARROW keys simultaneously to unlock.
7. Find the printer test named "Barcode Demo" and press the ENTER key.
8. The printer will return ONLINE automatically and print one demo page.
9. To demonstrate a bad bar code reading, block the scanning beam with an opaque object while the bar code moves under the beam. When you block the beam, the validator will generate a reading error and will perform a default error action. The default setting for *Validator > Control > Validator Action* is "Retry Form". Using the factory default settings, the printer will pull the label with the bad barcode back, overstrike the entire label, reprint the barcodes on the next label, and then stop.
10. Press the PAUSE key to take the printer OFFLINE.
11. Lock the panel again using the UP+DOWN ARROW keys.
12. Press the PAUSE key to place the printer back ONLINE.

2 *Operation*

Basic Validator Setup

Unit Positioning

The validator must be positioned so that the scanning beam covers the entire area containing the bar codes, including the area required for quiet zones. The beam width can be moved horizontally to the left or right (see “Shifting the Scanning Beam” on page 39).

If a bar code is completely outside of the scanning area, straddles an edge, or does not pass completely under the scanning beam, the validator interprets it as a missing bar code and generates error conditions.

Validator Front Panel

The front panel of the validator has the following controls and indicators:

- **POWER:** Indicates the validator is at full power.
- **CALIBRATION:** Flashes when the validator is in calibration mode. See page 39 for calibration instructions.
- **READ:** Flashes when the validator is reading a bar code.
- **1 and 2:** Used for maintenance purposes only.
- **RESET:** This button has three functions, depending on how long you hold the button down. See Table 3 below.

Table 3. RESET Button Settings

Time RESET Button Is Depressed	Result
Less than 2 seconds	Turns on the scanning beam
More than 4 but less than 6 seconds	Validator goes into calibration mode
More than 6 seconds	Resets validator to the last good calibration settings and turns off the scanning beam

WARNING Do not lift the printer by the validator unit or by the bracket.

WARNING The validator contains sensitive electronic equipment. Do not jar or drop the unit.

Validator Menu

The Validator section is structured into five submenus as follows:

- The **Control** submenu is used to configure how the validator will operate with respect to the results provided by the scanner. Those menus are described starting on page 46.
- The **Grading** submenu is used to configure grading criteria of the barcodes found by the validator. Those menus are described starting on page 54.
- The **Scanner** submenu is used to configure specific setup of the scanner. Those menus are described starting on page 58.
- The **Diagnostics** submenu is used to run test procedures to help determine the accuracy and troubleshoot the validator. Those menus are described starting on page 61.
- The **Statistics** submenu is general read-only and used to gather and report statistics on how the validator is reporting on print jobs sent to the printer. Those items are described starting on page 67.

The Validator menu structure and its defaults are summarized in Figure 31 and Figure 32.

Figure 31 Validator Section and Submenus

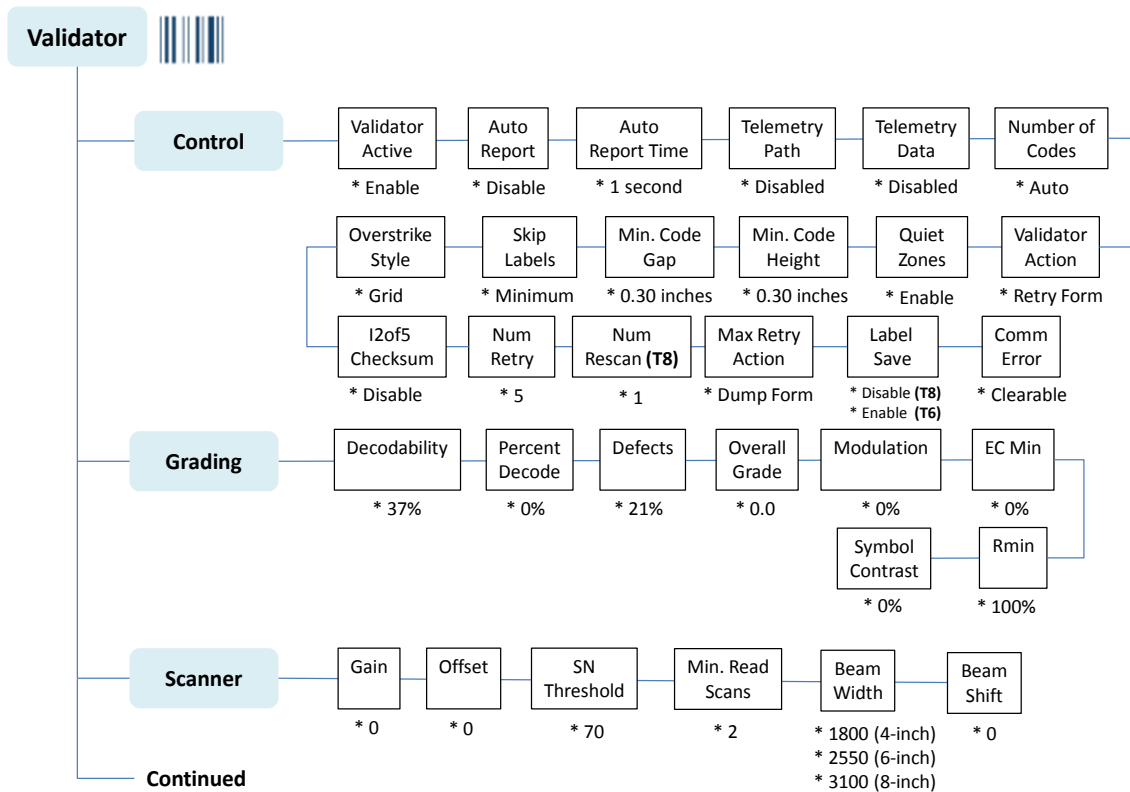
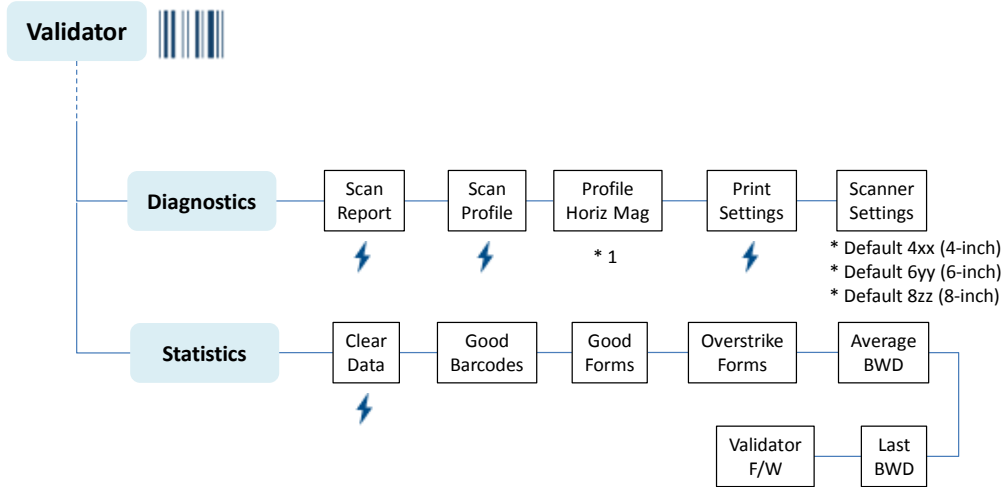



Figure 32 Validator Section and Submenus, Continued



Configuring the Validator

Configuring the validator is done by selecting the Validator icon  within the Settings section. The validator comes equipped with a default setting for each configuration option, and it works without having to change any of these options. However, in some cases it is necessary to adjust these options, which are described below.

IMPORTANT If you are unable to select the Validator icon or the icon is grey , then the validator is not properly installed. Refer to Section “Install the Validator” for information on how to install the validator.

IMPORTANT If you make any changes to the default configuration menu items, you will be prompted to save the configuration. See “Auto Save Configuration” in the *Administrator’s Manual*.

Enabling and Disabling the Validator

Software can automatically detect an installed validator when the printer is powered up. If the printer is powered up with *Configs > Control > Power-Up Config* set to “Factory”, the Validator icon can be selected and *Validator > Control > Validator Active* is set to “Enable”.

If Power-Up Config. is not set to Factory, the Validator icon can be selected, but *Validator > Control > Validator Active* is set to “Disable”. Set this menu to “Enable” and save the configuration as described in the *Administrator’s Manual*. In the same manner, the validator can be disabled.

IMPORTANT Do not disable or enable the validator with data in the buffer. See “Resetting Validator Data” page 45.

RFID Encoder

If you have an RFID encoder but are not encoding RFID tags, make sure RFID Reader is set to “Disable” in the *RFID > Control > RFID Active* menu, otherwise the validation process will slow down considerably as the RFID encoder attempts to scan for non-existent RFID tags.

Checking the Firmware Revision Number

For troubleshooting purposes, you may need to reference the Validator firmware revision number. This can be found in two different places within the Settings section:

- Validator > Statistics > Validator F/W.
- Tools > About > Validator F/W.

Validator Reporting

After any completed print job or Bar Code Demo page, you can request a report from the printer which describes the validation statistics since the printer was turned on, or since the last data reset, (resetting data is detailed at the bottom of this page).

Requesting a Validator Report

This procedure prints a summarized validator report. (This report also includes RFID data if the printer has an RFID encoder.)

1. Press the PAUSE key to take the printer OFFLINE.
2. If necessary, press the UP+DOWN ARROW keys at the same time to unlock the front panel.
3. Edit the menu *Tools > Print Tests > Run Tests*.
4. Find the printer test named “RFID/ODV Report” and press the ENTER key.
5. Lock the panel again using the UP+DOWN ARROW keys.
6. Press PAUSE again to put the printer ONLINE.

Defining the Output Destination (Telemetry Path)

You may want to send a streaming flow of validation data to an external device during the print job. By default, this function is disabled.

To enable this function, set the menu *Validator > Control > Telemetry Path* to “Network Port”. The printer then outputs the bar code analysis and underlying data from the validator to a device connected to the network port so the validator data can be seen and analyzed with the optional remote management software.

Selecting the Type of Report (Telemetry Data)

The validator sends a report to the selected data output destination. There are three different options controlled by the *Validator > Control > Telemetry Data* menu:

- **Short Report.** Default setting. Provides the encoded failure cause or pass indication and the bar width deviation, shown as a percentage.
- **Full Report.** Provides a completed report of all the data captured by the validator.
- **Validation Mode.** Provides the same data as the Short Report, but adds the actual bar code data read.

Resetting Validator Data

The validator reports on all bar codes it detects since the last data reset. For example, you print a large batch of labels with bar codes and then print a validator report. Then you print another batch of labels with bar codes and print another report. The report will contain information on both batch jobs. However, if you reset the validator data between batch jobs, the second report will only contain information on the second batch job.

To reset Validator Data, execute the menu *Validator > Statistics > Clear Data*.

Control Submenu

A number of validator options which define specific parameters for certain print jobs can be set from the printer configuration menu.

Validator Active

Validator > Control > Validator Active	
<p>Software can automatically detect an installed validator when the printer is powered up. If the printer is powered up with <i>Configs > Control > Power-Up Config</i> set to "Factory", the Validator icon can be selected and this option is set to "Enable".</p> <p>If <i>Power-Up Config</i> is not set to Factory, the Validator icon can be selected, but this option is set to "Disable".</p>	
Disable	The validator is disabled and not active.
Enable	The validator is enabled and active.
Factory Default	Depends on <i>Configs > Control > Power-Up Config</i> setting. See above.
IMPORTANT	Do not disable or enable the validator with data in the buffer. See "Resetting Validator Data" on page 45.
IMPORTANT	When exiting Power Saver Mode, about 20 seconds is required to re-initialize ODV. A message will be displayed alerting the user of the delay.

Auto Report

Validator > Control > Auto Report	
<p>This function allows you to disable or enable an automatic validator report printout after a batch job or Bar Code Demo page.</p>	
Disable	No automatic validator report is printed after the job.
Enable	The validator report is printed after the batch job. The end of the batch is determined by either the EXECUTE command or by timeout using <i>Validator > Control > Auto Report Time</i> to the desired value (1 to 10 seconds).
Print&Clear	Same functionality as <i>Enable</i> with the validator statistics are cleared after the report is printed. After the report is printed, the front panel message will display informing the user the statistics are reset.
Factory Default	Disable

Auto Report Time

Validator > Control > Auto Report Time	
This function allows you to set the timeout for the Auto Report in seconds. If the printer is idle for the set number of seconds, an Auto Report will be generated if Auto Report is set to Enable.	
Minimum	1 second
Maximum	10 seconds
Factory Default	1 second

Telemetry Path

Validator > Control > Telemetry Path	
You may want to send a streaming flow of validation data to an external device during the print job. By default, this function is disabled. To enable this function, set this menu Path to "Network Port". The printer then outputs the bar code analysis and underlying data from the validator to a device connected to the network port so the validator data can be seen and analyzed with the optional remote management software.	
Disabled	The validator does not send any data to an external device.
Network Port	The printer outputs the bar code analysis and underlying data from the validator to a device connected to the network port so the validator data can be seen and analyzed with the optional remote management software.
Factory Default	Disabled

Return Data

Validator > Control > Return Data	
<p>This option enables the validator to send data out the status port as defined by <i>System > Printer Mgmt > Ret. Status Port</i>. If <i>System > Printer Mgmt > Ret. Status Port</i> uses <i>E-NET Stat Port</i>, use <i>System > Printer Mgmt > Status Port Number</i> to set port.</p> <p>This feature is designed to work best with <i>Validator > Control > Validator Action</i> set to <i>Retry Form</i>.</p>	
Disable	No data will be returned through the status port.
Data+Grade	The following data will be sent out the status port for every barcode found: <i>Grade, Barcode Data <Carriage Return><Line Feed></i>
Data+Grade+Fail	In addition to barcode grades and data, a failure indication will be sent out the return status port if the validator fails a label Max Retry times: <i>FAIL<Carriage Return><Line Feed></i>
Factory Default	Disable
IMPORTANT	<p>When the menu is set to something other than <i>Disable</i>, the printer will automatically change <i>Validator > Control > Telemetry Data</i> to <i>Full Report</i> since it is required for the feature.</p> <p>If, however, the user subsequently changes <i>Telemetry Data</i> to something different, barcode grades data will no longer be returned.</p>

Telemetry Data

Validator > Control > Telemetry Data	
<p>The validator sends a report to the selected data output destination. There are three different options based on this menu.</p>	
Short Report	Default setting. Provides the encoded failure cause or pass indication and the bar width deviation, shown as a percentage.
Full Report	Provides a completed report of all the data captured by the validator.
Validation Mode	Provides the same data as the Short Report, but adds the actual bar code data read.
Factory Default	Short Report

Number of Codes

Validator > Control > Number of Codes	
<p>You can define how many bar codes the validator should expect on a form. This setting is required when bar codes are produced as a part of a larger bitmapped image. When set to a specific number, the printer checks after a form has printed and passed the validator and determines if it has received an analysis report for each bar code. If the printer does not have as many</p>	

	reports as it expects, it assumes a gross bar code failure.
Auto	The printer only expects as many bar code analyses as bar codes printed using printer bar code commands defined by the host software.
1-99	Set to number of bitmapped barcodes on the form.
Factory Default	Auto
IMPORTANT	The Postscript/PDF emulation cannot use Auto. It must have the number of codes set to the number of barcodes on the form.

Validator Action

Validator > Control > Validator Action	
	The printer response is the same whether the error stems from a bad or missing bar code. It is determined by the Validator Action setting. See Validator Action (Error Action) for more details on each one of these options.
Stop	If the validator detects a bar code failure, the print job stops.
Overstrike	Use Overstrike mode when you want bad labels to be marked, but not reprinted.
Retry Form	This mode is similar to the Overstrike mode. However, instead of resuming printing where the printer had left off, the printer will attempt to reprint the bad form.
Stop & Retry	The printer will stop printing and display the error message. After the error message is cleared and the appropriate labels are skipped from <i>Validator > Control > Skip Labels</i> , it will reprint the bad form and any other forms printed prior to the physical stop.
Grade&Report	The entire print job will print uninterrupted. If one or more errors is detected, the printer status indicator lamp flashes, the alarm sounds, and the error message "Bar code fails / Job has errors" displays.
Rescan Form (T8000 only)	Similar to the Retry Form mode, however, instead of backing up and overstriking the form, the printer will back up and rescan the bad form and any other forms that have already printed.
Rescan&Retry (T8000 only)	Similar to Rescan Form with one exception: after the printer has rescanned the form and overstruck it if there was still a fault, it will reprint and rescan the same form again.
Rescan&Stop (T8000 only)	Similar to the Retry Form mode, however, instead of backing up and overstriking the form, the printer will back up and rescan the bad form and any other forms that have already printed.
Factory Default	Retry Form
IMPORTANT	On T6000 printers the maximum overstrike distance is limited to about one (1) inch.

Quiet Zones

Validator > Control > Quiet Zones	
<p>Quiet zones are the white spaces surrounding the bar code. Each bar code requires a minimum quiet zone distance in order for the bar code to be scanned properly.</p> <p>The validator requires a minimum distance of 1/2" or 20 times the minimum element width (x-dimension), whichever is greater, between bar codes.</p>	
Disable	The quiet zone is not included in pass/fail criteria.
Enable	The bar code quiet zone is included as part of the pass/fail criteria.
Factory Default	Enable
IMPORTANT	The validator does not recognize x-dimensions greater than 40 mil with Quiet Zones enabled.

Min. Code Height

Validator > Control > Min. Code Height	
<p>Set Min. Code Height to the height of the shortest bar code on the label. By changing the Min. Code Height, the printer and slew speeds will be changed automatically. This value can be set in 0.01 inch increments.</p>	
Minimum	0.13 inches
Maximum	1.00 inches
Factory Default	0.30 inches
IMPORTANT	For more information, see Section "Print Speed Limits" on page 68.

Min. Code Gap

Validator > Control > Min. Code Gap	
<p>This menu represents the distance between the closest bar codes within a print job. This value can be set in 0.01 Inch increments.</p>	
Minimum	0.15 inches
Maximum	1.00 inches
Factory Default	0.30 inches
IMPORTANT	For more information, see Section "Print Speed Limits" on page 68.

Skip Labels

Validator > Control > Skip Labels	
This option is used for skipping blank labels after bad labels have been marked. It is useful when you want to have extra blank labels in between bad and good ones.	
Minimum	Up to one blank label skipped.
Maximum	Up to two blank labels skipped.
Factory Default	Minimum
IMPORTANT	Minimum and Maximum blank labels are only applicable for forms 2 inches (5.08 cm) high or more. For labels less than 2 inches high, the minimum and maximum blank labels may vary.

Overstrike Style

Validator > Control > Overstrike Style	
This option is used for marking bad labels with different overstrike styles: Grid (the default), Grey, Checkerboard, or Error Type Msg.	
Grid	Grid Pattern
Grey	Grey Pattern
Checkerboard	Checkerboard Pattern
Error Type Msg	Error Msg with type of failure will overwrite label
Factory Default	Grid
IMPORTANT	If you are using an RFID encoder, set the validator Overstrike Style different than the <i>RFID > Control > Overstrike Style</i>. This will help you differentiate between a validator error and an RFID error.
IMPORTANT	On T6000 printers the maximum overstrike distance is limited to about one (1) inch.

I2of5 Checksum

Validator > Control > I2of5 Checksum	
This option allows you to include or exclude the checksum option in the Interleaved 2 of 5 code as part of the grading. A Checksum Failure error will display if enabled and a checksum digit is not included.	
Disable	Checksum is not required for a passing Interleaved 2 of 5 barcode.
Enable	Any incoming Interleaved 2 of 5 data without checksum digits will be graded as a failure.
Factory Default	Disable

Num Retry

Validator > Control > Num Retry	
This option allows you to set the number of times a form will be reprinted before the printer stops. After you clear the error message, the printer will print the same form or the next form, depending on the setting for Max Retry Action (see “Max Retry Action” below).	
Minimum	3
Maximum	5
Factory Default	5
IMPORTANT	This setting is utilized only when Validator Action is set to Retry Form, Stop & Retry, or Rescan&Retry. See “Validator Action (Error Action)” on page 71.

Num Rescan (T8000 only)

Validator > Control > Num Rescan	
This option allows you to set the number of times a form will be rescanned before the printer stops. After you clear the error message, the printer will print the same label or the next label, depending on the setting for Max Retry Action (see “Max Retry Action” below). This is only supported on the T8000.	
Minimum	1
Maximum	5
Factory Default	1
IMPORTANT	This setting is utilized only when Validator Action is set to Rescan, Rescan&Retry, or Rescan&Stop. “Validator Action (Error Action)” on page 71.

Max Retry Action

Validator > Control > Max Retry Action	
This option determines what the printer will do with the current form once the Num Retry or Num Rescan counter has been exhausted (see “Num Retry” or “Num Rescan” above).	
Dump Form	After you clear the fault the form will be dumped and printing will resume with the next form.
Keep Form	After you clear the fault printing will resume with the same form again. It will not attempt to print the next form until the problem form has printed correctly.
Factory Default	Dump Form
IMPORTANT	This setting is utilized only when Validator Action is set to Retry Form, Stop & Retry, Rescan Form, Rescan&Retry, or Rescan&Stop. “Validator Action (Error Action)” on page 71.

Label Save

Validator > Control > Label Save	
The printer will often be printing a label when it determines that the label printed before the immediate label was defective.	
Disable	When set to disable, the printer pulls both labels back, overstrikes them and then reprints them.
Enable	With Label Save enabled, the ODV will accept or reject the label it just printed before it prints the next label. When a label is found defective, it will only overstrike that label.
Factory Default	Disable (T8000)
	Enable (T6000)
IMPORTANT	Label Save enabled causes a slight throughput reduction.

Comm Error

Validator > Control > Comm Error	
This menu allows the 'Validator not communicating' error to be clearable by the user or not clearable by the user.	
Not Clearable	The user must resolve the error and recycle the printer power in order to print.
Clearable	The user will be able to clear the fault and print jobs. Barcodes in these jobs will not be validated.
Factory Default	Clearable

Verify Start

IMPORTANT This feature (along with *Verify Stop* menu) requires a Feature File. Contact your local support person or refer to the Printronix Customer Support Center on page 82.

Validator > Control > Verify Start	
<p>Indicates where scanning will begin (distance from leading edge of the form). When <i>Validator > Control > Verify Stop</i> is set to 0 (the default), the feature is disabled, and the validator will behave as normal.</p> <p>When <i>Verify Stop</i> is non-zero, the validator will only search between <i>Verify Start</i> and <i>Verify Stop</i> distances. All barcodes outside of this region will be ignored. All barcodes inside this region will be verified and counted.</p>	
Minimum	0.0 inches
Maximum	99.0 inches
Factory Default	0.0 inches
IMPORTANT	<p>If <i>Validator > Control > Number of Codes</i> is set to <i>Auto</i>, the beam will be turned on 1/8" prior to the first picket barcode in that specified region, and it will be turned off 1/8" after the last picket barcode.</p> <p>If <i>Number of Codes</i> is not <i>Auto</i> (i.e., bitmap barcodes), the beam will always be turned on at the <i>Verify Start</i> distance and turned off at the <i>Verify Stop</i> distance.</p>
IMPORTANT	A maximum of 10 picket barcodes per form can be supported in this mode.
IMPORTANT	The user must set the <i>Verify Start</i> and <i>Verify Stop</i> values such that the barcodes they want graded are fully included in the scanning zone.

Verify Stop

IMPORTANT This feature (along with *Verify Start* menu) requires a Feature File. Contact your local support person or refer to the Printronix Customer Support Center on page 882.

Validator > Control > Verify Stop	
While <i>Validator > Control > Verify Start</i> specifies where scanning begins, this menu indicates where scanning ends (distance from leading edge of the form). When set to 0 (the default), the feature is disabled, and the validator will behave as normal.	
Minimum	0.0 inches (or greater <i>Verify Start</i> if enabling feature).
Maximum	99.0 inches
Factory Default	0.0 inches (Feature Disabled)
IMPORTANT	See full description with important notes with <i>Verify Start</i> on the top of this page.

Grading Submenu

The following menus are in the *Validator > Grading* section and used to configure how the barcodes are graded. The Overall Grade is determined by taking the lowest grade obtained for any of these bar code quality parameters. See Section “Overall Grade Calculations” for details and examples.

Decodability

Validator > Grading > Decodability	
You can determine how strict the validator grades the wide/narrow bars and spaces which compose the bar code by setting the Decodability parameter to a percentage value from 30% to 90%. The higher the percentage value chosen, the stricter the validator grades.	
Minimum	30%
Maximum	90%
Factory Default	37%
IMPORTANT	This parameter factors into the Overall Grade (page 56).

Percent Decode

Validator > Grading > Percent Decode	
You can set how strict the validator grades each bar code. For example, setting Percent Decode to 60% means that 60% of the scanned bar code must be readable for the validator to give the bar code a passing grade. The higher the percentage value chosen, the stricter the validator grades.	
Minimum	0%
Maximum	99%
Factory Default	0%
IMPORTANT	This parameter factors into the Overall Grade (page 56).

Defects

Validator > Grading > Defects	
You can set how strict the validator grades the irregularities such as voids and spots found within elements and quiet zones for each bar code. For example, the Defects default is 21%. This means that if the bar code and	

quiet zone defects exceed 21%, the validator gives the bar code a failing grade. The lower the percentage value chosen, the stricter the validator grades.	
Minimum	0%
Maximum	100%
Factory Default	21%
IMPORTANT	This parameter factors into the Overall Grade (page 56).

Overall Grade

Validator > Grading > Overall Grade	
<p>This menu item sets the value used by the validator for pass/fail threshold during the analysis of bar codes. Instead of a letter grade, numbers are used to allow for more resolution. Higher values create a stricter pass criterion. The numbers can be translated to letter grades per below:</p> <p style="margin-left: 40px;">Letter Grade A = 3.5 to 4.0 range Letter Grade B = 2.5 to 3.4 range Letter Grade C = 1.5 to 2.4 range Letter Grade D = 0.5 to 1.4 range Letter Grade F = 0.0 to 0.4 range</p> <p>The Overall Grade is determined by taking the lowest grade obtained for any of these bar code quality parameters: Decodeability, Percent Decode, Defects, Modulation, EC Min, Rmin, and Symbol Contrast.</p>	
Minimum	0.0
Maximum	4.0
Factory Default	0.0
IMPORTANT	Any bar code with a grade below this threshold value will cause the printer to display the Overall Grade Fail error message (see “Error Messages” on page 75) and take the appropriate error action.

Modulation

Validator > Grading > Modulation	
<p>Modulation measures how well the scan laser sees the wide elements (bars or spaces) relative to the narrow elements. In general, scanning lasers see bars better than spaces and wide elements better than the narrow elements. This menu item sets the value used by the validator for pass/fail threshold during the analysis of bar codes. Higher values create a stricter criterion for passing.</p>	
Minimum	0%
Maximum	100%
Factory Default	0%
IMPORTANT	This parameter factors into the Overall Grade, shown above.

EC Min

Validator > Grading > EC Min	
This menu item sets the minimum edge contrast, which is the worst edge transition (bar to space or space to bar) used by the validator for pass/fail threshold during the analysis of bar codes. Bar codes with an edge contrast below this threshold will fail. The higher the value, the stricter the criterion for passing.	
Minimum	0%
Maximum	100%
Factory Default	0%
IMPORTANT	This parameter factors into the Overall Grade (page 56).

RMin

Validator > Grading > RMin	
This menu item sets the minimum reflectance value used by the validator for pass/fail threshold used during the analysis of bar codes. A bar code will fail if all the bar reflectance values are above the percentage of space reflectance set by this threshold. For example, an Rmin setting of 50% requires that at least one bar reflectance value fall under the midpoint of the reflectance value read for the highest space reflectance.	
Minimum	0%
Maximum	100%
Factory Default	100%
IMPORTANT	This parameter factors into the Overall Grade (page 56).

Symbol Contrast

Validator > Grading > Symbol Contrast	
Symbol Contrast represents the contrast between the bars and spaces in the bar code used by the validator for pass/fail threshold used during the analysis of bar codes. The bar code must have a certain level of contrast to be recognized by the validator. Bar codes with a symbol contrast below the threshold will fail. The higher the value, the stricter the criterion for passing.	
Minimum	0%
Maximum	100%
Factory Default	0%
IMPORTANT	This parameter factors into the Overall Grade (page 56).

Overall Grade Calculations

The validator follows the specified algorithm defined in the ANSI X3.182 specification for determining the Overall Grade based on an average. Although it is not defined, the validator truncates the result of all analysis parameters averages for a slightly stricter grading.

A side effect of the ANSI specified algorithm is that the Overall Grade may be lower than any of the averaged analysis parameters. This occurs because the Overall Grade is based on the lowest grade on any scan converted to a single digit grade (A to F, 4 to 0) which is then averaged. This usually occurs when a single analysis parameter has a value just above or just below the Overall Grade.

Example

The Decodeability value of 51 displays as B, but the Overall Grade displays as C.

The bar code was scanned five times: three scans had values of 0.49 (grade C) and two scans had values of 0.54 (grade B).

The Decodeability grading calculation is:
 $(3 \times 0.49) + (2 \times 0.54) = 2.55$
 $2.55 \div 5 = 0.51$ (grade B)

The Overall Grade calculation is:
 $(3 \times 2.0) + (2 \times 3.0) = 12$
 $12 \div 5 = 2.4$ (grade C)

Also, with certain combinations of multiple analysis parameters and possibly the truncation used on the analysis parameter's average, the Overall Grade may be higher than an individual analysis parameter grade.

Example

The Decodeability value of 48 displays as C, but the Overall Grade displays as B.

The bar code was scanned five times: four scans had values of 0.51 (grade B) and one scan had a value of 0.40 (grade C).

The Decodeability grading calculation is:
 $(4 \times 0.51) + (1 \times 0.40) = 2.44$
 $2.44 \div 5 = .49$ (grade C)

The Overall Grade calculation is:
 $(4 \times 3.0) + (1 \times 2.0) = 14$
 $14 \div 5 = 2.8$ (grade B)

Scanner Submenu

The following menus are in the *Validator > Scanner* section and used to configure the scanner of the validator.

Gain

Validator > Scanner > Gain	
This menu item sets the scanner gain setting (when a non-zero value is set). This allows you to adjust the amplitude (height) of the space/bar transitions as seen on a Scan Profile to optimize the validator hardware for applications where standard settings make the bar codes unreadable.	
Minimum	0
Maximum	255
Factory Default	0
IMPORTANT	If you want the validator to automatically adjust its Gain setting during a validator calibration, set Gain = 0 and Offset = 0. Gain and Offset are automatically adjusted during calibration only if both Gain = 0 and Offset = 0

Offset

Validator > Scanner > Offset	
This menu item sets the scanner offset setting (when a non-zero value is set). This allows you to adjust the vertical position of the Scan Profile to guarantee that the validator hardware is reading the bar codes within the optimal range. You can adjust this to place the bar code profile in the center of the profile scale above 10% and below 90%.	
Minimum	0
Maximum	255
Factory Default	0
IMPORTANT	If you want the validator to automatically adjust its Offset setting during a validator calibration, set Gain = 0 and Offset = 0. Gain and Offset are automatically adjusted during calibration only if both Gain = 0 and Offset = 0

SN Threshold

Validator > Scanner > SN Threshold	
This menu item sets the SN (signal to noise) threshold used by the validator to discriminate between high peak noise and actual bar code transitions. Any reflectance transitions that are below the threshold are ignored and considered noise.	
Minimum	5
Maximum	199
Factory Default	70

Min. Read Scans

Validator > Scanner > Min. Read Scans	
<p>This menu item sets the minimum number of scans per bar code that must be read. If less than the minimum number is read, then the “Unscannable / xx Missing Codes” error message is generated.</p> <p>To ensure that the validator accurately validates the bar codes, set the Min. Read Scans value to 75% of the number of scans possible per bar code (rounded down). Use this formula to determine the number of scans possible per bar code in relation to print speed and bar code height:</p> $\frac{100 \times \text{Bar Code Height In Inches}}{\text{Print Speed (Inches Per Second)}} = \text{Possible Scans (rounded down)}$ <p>Set Min. Read Scans to 75% of the Possible Scans value.</p>	
Minimum	2
Maximum	99
Factory Default	2
IMPORTANT	<p>If you have more than one bar code on the form, use the shortest bar code for the calculation.</p> <p>Example: For a 0.5 inch tall bar code printing at 4 IPS: $(100 \times 0.5) / 4 = 12$ Possible Scans (rounded down) Set Min. Read Scans to 75% of 12 = 9</p>

Beam Width

Validator > Scanner > Beam Width	
<p>This menu item allows you to adjust the width of the scanning beam to focus on specific areas where bar codes are expected. This will reduce the amount of data the validator must process. Use this to read bar codes near text or graphics that may interfere with the validator if the text or graphics are scanned.</p> <p>Reducing the beam width and focusing it to specific areas also reduces light reflection interference to the validator from the media, ribbon, tear bar, or other shiny surfaces. The higher the value, the wider the beam width.</p>	
Minimum	250
Maximum	3100
Factory Default	4-inch printers: 1800 6-inch printers: 2550 8-inch printers: 3100
IMPORTANT	<p>The beam may need to be moved horizontally. See “Beam Shift” option.</p>

Beam Shift

Validator > Scanner > Beam Shift	
This option enables you to shift the scanning beam horizontally to the left or right. The left edge of the beam should be approximately 0.25 inches (6.35 mm) from the left edge of the tear bar. Keep selecting the new value until the beam width is at the desired position. Lower values will move the beam to the left.	
Minimum	-99
Maximum	99
Factory Default	0

Diagnostics Submenu

The following items are in the *Validator > Diagnostics* section and used to configure the scanner of the validator using the following menu options:

- Scan Report
- Scan Profile
- Profile Horiz Mag
- Print Settings
- Scanner Settings

Scan Report

IMPORTANT To print a Scan Report, *Validator > Control > Telemetry Data* must be set to the option “Full Report”.

This executable menu item prints a diagnostic printout of bar code analysis parameters calculated by the validator. It allows you to determine which parameter may be the cause of bar code verification failures. The report printed is based on the last Full Report received from the validator. This allows you to send a bar code print job to the printer, have the bar code scanned by the validator, and view a report of the parameters as seen by the validator.

For forms with multiple bar codes, only information from the last scanned bar code will be included in the report. To view validator parameters for all bar codes on a form, use the Online Data Validator Data Manager software.

IMPORTANT If the label is not wide enough, not all of the information will print.

The printed report is generated from validator reports received by the printer during printing. The report does not include information about bar codes that are placed in the validator scanning beam while the printer is idle or from print jobs that generate an “Unscannable: xx Missing Codes” error message.

The number of Total Scans and Good Scans can help you determine if the print speed is set too high and causing borderline failures by not allowing for enough scans to be done by the validator. The Scan Report is based on the last Full Report received by the validator. So if the last bar code printed is positioned close to the last inch of the form, and on-demand printing occurs to force the last bar code to be fed past the laser beam, the Total Scans and Good Scans reported will not be the same as those reported by the validator when printing at the set *Media > Speed > Print Speed*. This is because the on-demand printing portion is done at a fixed print speed which may be higher or lower than the set Print Speed. For example, a bar code printed at 7 ips may yield eight Total Scans, but if printed in an on-demand printing mode it may yield 18 Total Scans.

Scan Report Information

1. "ERROR:" followed by highest priority failure message (if an error other than "Unscannable Code" occurred) or "None" if no error occurred
2. Printout of characters read from the bar code
3. Symbology Type Read (e.g. Code 39, Code 128, etc.)
4. Overall Grade (letter grade and calculated/number value)
5. X dimension (mils)
6. Decodeability (%)
7. Modulation (%)
8. Symbol Contrast (%)
9. EC (Average Edge Contrast) (%)
10. Defects (%)
11. Rmin/Rmax (reflectance min/max)
12. PCS (Print Contrast Signal)
13. Percent Decode (%)
14. Bar Deviation Avg (%)
15. Min. Bar Deviation (%)
16. Max. Bar Deviation (%)
17. Ratio
18. Good Scans
19. Total Scans

The following is a sample scan report of a Code 39, 10 mil bar code containing "PTX8702" with a quiet zone violation:

SCAN REPORT

ERROR: Bar code quiet zone too small	
Barcode Data:	[ST]PTX8702[ST]
Symbology	Code 39
Overall Grade	C (2.1)
X dimension (mils)	09.9
Decodeability (%)	65
Modulation (%)	34
Symbol Contrast (%)	68
Edge Contrast (%)	30
Defects (%)	14
Rmin/Rmax	2
PCS	92
Percent Decode (%)	100
Bar Deviation Avg (%)	-16
Min. Bar Deviation (%)	-31
Max. Bar Deviation (%)	-4
Ratio	2.0
Good Scans	28
Total Scans	30

Scan Profile

This is an executable menu that prints the scan reflectance profile of a bar code placed in the validator scanning beam.

IMPORTANT: You will need a minimum installed label width of 2 inches to support the Scan Profile printout.

1. Press the PAUSE key to take the printer OFFLINE.
2. If necessary, press the UP+DOWN ARROW keys at the same time to unlock the front panel.
3. Find *Validator > Diagnostics > Scan Profile*.
4. Place a bar code in the scanning beam path.
5. Press ENTER key to scan the bar code.
6. When prompted on the control panel, remove the scanned bar code.
7. Press ENTER key to print the scan profile.
8. Lock the panel again using the UP+DOWN ARROW keys.
9. Press PAUSE again to put the printer ONLINE.

The length of the scan profile printed is proportional to the *Validator > Scanner > Beam Width* setting and depends on the *Validator > Diagnostics > Profile Horiz Mag* setting.

The scan profile will print either a 1.5 inch wide or a 3 inch wide graph depending on the *Media > Image > Label Width* setting. (Label widths less than 4 inches print the smaller 1.5 inch wide profile.)

IMPORTANT: Printing is done in continuous mode without taking into account media gap/marks. Use continuous media or else the scan profile may distort at the media gap/marks.

The following figure shows a sample scan profile graph. It only shows the profile of actual bar code data. The dashed lines represent the 90% and 10% marks. You can use these to help set the gain and offset (if necessary).

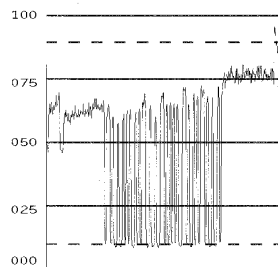

Figure 33 Sample Scan Profile

Profile Horiz Mag

Validator > Diagnostics > Profile Horiz Mag	
This menu item selects the horizontal magnification for printing the scan profile. This allows you to zoom in on the profile. Magnification values are multiples of the scan profile length printed for a given <i>Validator > Scanner > Beam Width</i> setting. For example, if the Beam Width setting of 1800 prints a 4 inch scan profile, a Profile Horiz Mag setting of 2 prints an 8 inch scan profile.	
Minimum	1
Maximum	4
Factory Default	1

Figure 34 shows a Profile Horiz Mag setting of 2 for the same scan profile shown in Figure 33, page 63 (Profile Horiz Mag setting of 1).

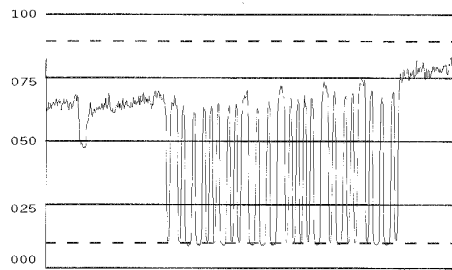

Figure 34 Sample Scan Profile: Profile Horiz Mag = 2

Print Settings

This is an executable menu item that reads and prints the settings used by the validator.

The response received from the validator after sending the ~DV (retrieves version), ~HT (retrieves hardware settings), and ~PT8 (retrieves parameter settings) commands are printed. Use the printout to view all the active settings the validator is using and to determine if there is any invalid setting which may be causing problems.

The following is a sample printout:

```
F/W Version: X354

~HT Response:
[~HS###]SOS= 025
[~HP###]Beam Shift= 000 024
[c]HIGHcal= 088
[c]LOWcal= 004
[~Sh##]= 088
[~Sl##]= 004
[c]SCfact= 044
[c]min cal= 031
[~HB#]baud= 003
[~LL]smt_decode=343
[~LM##]chars= 003
[~LN##]num_bc= 001
[~LZ##]num_bc_exact= 000
[~LR#]No_Read_Enable=000
[~LF##]I25_Mod10_Chk=000
[~HQ#]output_mode= 001
[~HO#]oper_mode= 001
[~LA##]ansi= 005
[~LS##]min_scn= 003
[~LT#]sync_in= 001
[~LP#]sync_pol= 000
[~LX#]sync_typ= 001
[~LV##]sync_md= 000
[~PO#]port_sel= 005
[PC#]port_clear_md= 000
[Pt##]port_time= 099
[~LD##] %dec= 075
[~PR#####]PRST= 000200
[~HL#]ladder_code= 000
[~HJ#####]ladd_start= 0200
[~HK#####]ladd_end= 4000
[~HC#####]ana_len= 1800
[~HG#####]ana_lenh= 0950
```



```
[~HN####]pana_len= 0950
[~HU####]freq= 400
[~HV####]GTLA_len= 199
[~HY####]snoise= 070
[~HX####]dist= 084
[~H=#]dyn_out= 000
[~H!###]zone_tol= 450
[~H@##]gt_%= 043
[~SN###]#scans= 050
[~Lp#]part= 000
[~Lt#]itfp= 000
[DACs]= 178 151 255 255
[~LQ#]p_out= 000
[~Lw,d]def= 000 000
[~L*]pnet= 000
[~LC##]l25min= 000
[~H###]NTrys= 010
[~OS#]Data_Output= 000
[~Hs#]RunSpeed= 000
[~SS#####]CntlChars=013 010
[~Lm#####]DataCmpr= 00 00 (Locked)
[~SW#]NetworkXmit= 000
```

~PT8 Response

Port Status:

Global HW: 001

Global SW MIRR: 001

PORT STATE: 000

PASS/FAIL PARAMETERS:

```
001 - 255 255
002 - 040 000
003 - 255 255
004 - 050 000
005 - 255 255
006 - 020 004
007 - 255 255
008 - 255 255
009 - 255 255
010 - 255 255
011 - 255 255
012 - 255 255
013 - 255 255
014 - 255 255
015 - 255 255
016 - 255 255
017 - 255 255
018 - 255 255
019 - 255 255
020 - 255 255
021 - 255 255
022 - 255 255
023 - 255 255
024 - 255 255
025 - 255 255
026 - 255 255
```

Scanner Settings

This option has two purposes:

- Allows the validator to upload an optimized setting for a particular printer size at power up. This will use the full scanner beam width and improve the performance and efficiency of the validator.
- Allows you to customize a special scanner setting for a specific application. The feature file can then be downloaded to the printer by using normal printer download procedures and must be saved as part of the power up configuration. For more information, contact the Printronix Customer Support Center. See “Contact Information” on page 82.

To set this option when a feature file has been downloaded:

1. Press the PAUSE key to take the printer OFFLINE.
2. If necessary, press the UP+DOWN ARROW keys at the same time to unlock the front panel.
3. Edit the menu *Validator > Diagnostics > Scanner Settings*.
4. Scroll through the options: Default or feature file 1, feature file 2, etc. (up to seven feature files). The default is Default 4xx, Default 6yy, or Default 8zz (4, 6, and 8 inch printers respectively; xx, yy, and zz are file revision numbers).
5. Press ENTER key to accept the desired selection.
6. Save this configuration and set it as the Power-Up configuration in the *Configs > Control* section.
7. Cycle power for the new setting to take effect.
8. The beam may need to be moved horizontally. See *Validator > Scanner > Beam Shift*.

Statistics Submenu

Clear Data

Validator > Statistics > Clear Data	
<p>The validator reports on all bar codes it detects since the last data reset. For example, you print a large batch of labels with bar codes and then print a validator report. Then you print another batch of labels with bar codes and print another report. The report will contain information on both batch jobs. However, if you reset the validator data between batch jobs, the second report will only contain information on the second batch job.</p> <p>This executable menu will clear all the statistics shown in this Statistics submenu.</p>	
IMPORTANT	The beam may need to be moved horizontally. See “Beam Shift” option.

Good Barcodes

Validator > Statistics > Good Barcodes
The number of bar code reports sent from the validator since the last Clear Data command.

Good Forms

Validator > Statistics > Good Forms
The number of good (non-overstruck) forms printed since the last Clear Data command.

Overstrike Forms

Validator > Statistics > Overstrike Forms
The number of forms containing a bar code that fell below the minimum acceptable level since the last Clear Data command.

Average BWD

Validator > Statistics > Average BWD
The average of all Bar Width Deviations reported since the last Clear Data command, shown as a percentage.

Last BWD

Validator > Statistics > Last BWD
The Bar Width Deviation included in the most recent report received from the validator, shown as a percentage.

IMPORTANT A bar code’s Bar Width Deviation is determined by comparing the bar width the validator expects to the bar width that is actually printed. For example, if the bar width is printed exactly as the validator expects, the BWD is 0%. However, if the bar width as printed is 25% wider or narrower than the validator expects it to be, it reports a BWD of 25%.

Validator F/W

Validator > Statistics > Validator F/W
Shows the firmware version installed in the Validator.

Operation

There are a number of factors which contribute to successful bar code validation, including printer speed, on-demand print settings, calibration, and ambient light. The following sections describe how to ensure your bar code validator is scanning and reporting properly.

Print Speed Limits

Two factors in the validation process affect the printer's speed limit: minimum code height (bar code height) and minimum code gap. The printer automatically examines *Validator > Control > Min. Code Height* and *Validator > Control > Min. Code Gap* values and sets the defined maximum slew (vertical paper movement) and print speeds to insure proper operation. If the current *Media > Speed > Print Speed* and/or *Media > Speed > Slew Speed* values are higher than the newly defined maximum, the values are changed to equal the maximum. If the current values are lower than the newly defined maximum, no change in speed occurs.

Min. Code Height (Bar Code Height)

The validator cannot function at the highest speed possible by the printer. It requires a minimum number of scans per bar code to make a reliable assessment, so the speed of the printer is limited by the height of the bar code. If the bar code is very short, printing needs to be slowed down to allow sufficient scans to occur. If the print speed exceeds this limit, the message "Speed Exceeds Validator Limit" will display. Print speed will be lowered automatically if required, but will not automatically reset to a higher speed.

The printer cannot predict how high all the bar codes in a given job will be, so it cannot automatically limit or adjust the print speed to insure the code height/speed requirement is being met. When the bar code is too short for the selected speed, the printer produces a missing bar code error condition. Therefore, printer speed must be set manually to compensate for bar code height.

Use this formula to determine printer speed in relation to bar code height:

$$\frac{\text{Bar Code Height In Inches}}{0.030} = \text{Maximum Printer Speed In Inches Per Second}$$

Validator > Control > Min. Code Height	
Set Min. Code Height to the height of the shortest bar code on the label. By changing the Min. Code Height, the printer and slew speeds will be changed automatically. This value can be set in 0.01 inch increments.	
Minimum	0.13 inches
Maximum	1.00 inches
Factory Default	0.30 inches
IMPORTANT	The printing and slew speeds will be changed after the ENTER key is pressed.
IMPORTANT	Printer Speed can also be set manually by adjusting the <i>Media > Speed > Print Speed</i>.

Min. Code Gap

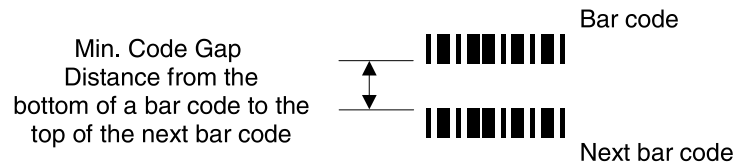

Minimum Code Gap represents the distance between the closest bar codes within a print job. The distance is measured from the bottom of one bar code to the top of the next bar code. The closest bar codes can be located on two separate labels or on the same label.

This distance is important because it affects how fast the *Media > Speed > Print Speed* can be set. If the bottom-most bar code on one label is very close to the top-most bar code on the next label, the printer could have trouble distinguishing which bar code correlates with which label.

Use this formula to determine printer speed in relation to minimum code gap:

$$\frac{\text{Min. Code Gap In Inches}}{0.050} = \text{Maximum Printer Speed In Inches Per Second}$$

Validator > Control > Min. Code Gap	
This menu represents the distance between the closest bar codes within a print job. This value can be set in 0.01 inch increments.	
Minimum	0.15 inches
Maximum	1.00 inches
Factory Default	0.30 inches
IMPORTANT	To avoid the risk of miscorrelation, the printer automatically sets its Print Speed based on the information that has been selected to ensure validation results are accurate.

On-Demand Printing

In order for each bar code to be successfully validated, the entire bar code must pass completely under the scanning beam, even when the printer is set up for on-demand printing. In cases where the bar code is close to the bottom of a label and the printer is in an on-demand printing mode, the printer automatically pushes the label past the scanning beam. Once the bar code is validated, the printer retracts the label back to be cut or torn off.

Because the printer has to push out and then retract labels in on-demand printing modes, the extra movements slow the printing process. You can avoid this by adjusting the form so that the bar code appears early enough on the form so that it will pass completely under the scanning beam during normal printing. This may involve rotating the form or moving the bar code to a different position on the form.

Bar Code Failures

The validator tells the printer to announce a fault condition in two situations:

- When the validator detects a bad bar code
- When the validator detects no bar code where it expects to find one.

How the printer reacts to these faults is determined by the printer's configuration settings, as described in this section.

Process for Barcode Analysis

The following flow chart is an overview of how the validator performs the barcode analysis.

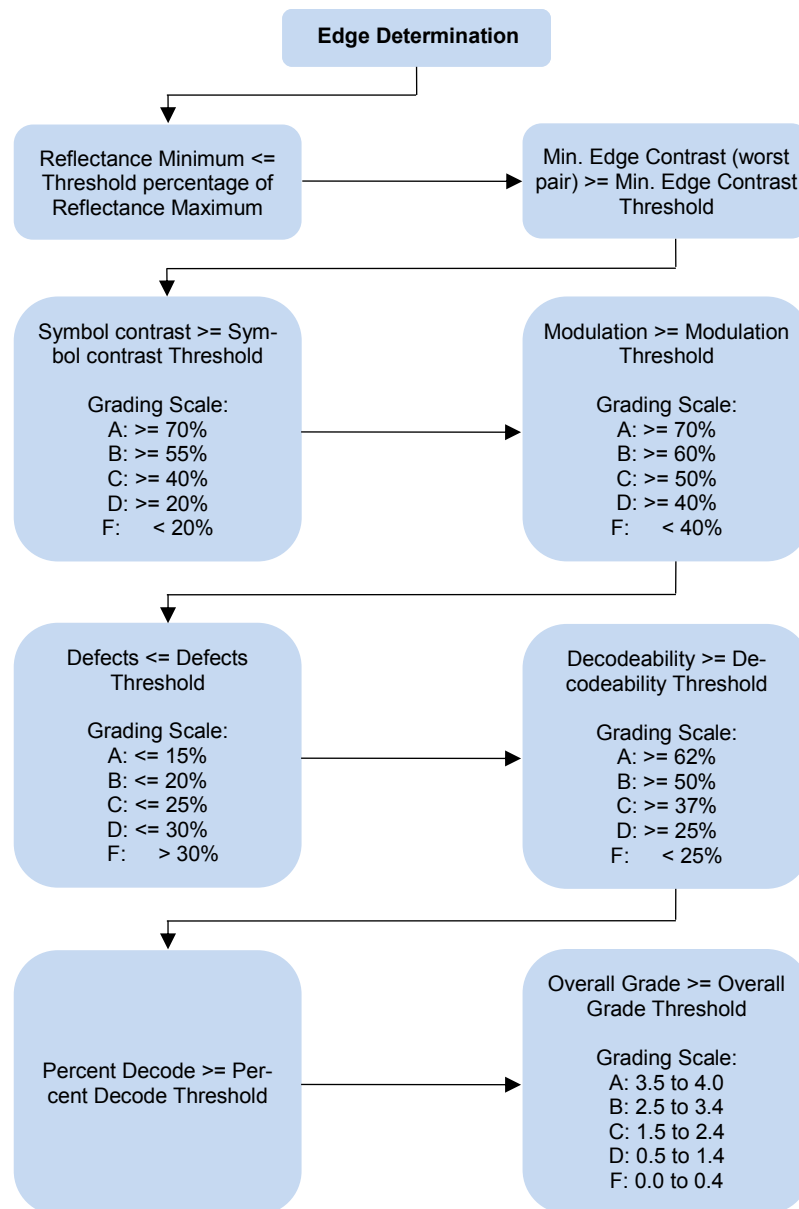

Figure 34 Barcode Analysis Flowchart

Bad Bar Code Error Detection

The validator examines every bar code that passes under the scanning beam and sends an analysis report to the printer. If a bar code is reported to have failed to meet any of the acceptance criteria, an error condition is reported. How the printer then reacts is described in “Validator Action (Error Action)”, detailed below.

Missing Bar Code Error Detection

A bar code may print so poorly that the validator cannot detect it, and the printer does not receive an analysis report for the code. To catch this problem, the printer tracks the position of the last label printed and knows when it should have completely passed the scanning beam. It can then compare the number of bar code analysis reports it expected, to the number it received. If the printer does not receive enough bar code reports, it enters an error condition. How the printer then reacts is described in “Validator Action (Error Action)”, detailed below.

The number of bar codes expected is determined one of two ways:

- If Auto is selected for the *Validator > Control > Number of Codes* parameter, the printer compares the number of bar code commands it receives from the software to the number of analysis reports it receives from the validator.
- You can set the number of bar codes generated by a bitmapped image that the printer should expect per form by selecting a value in the *Validator > Control > Number of Codes* parameter. **This option must be used with the Postscript/PDF firmware.**

For more information on choosing a value for the Number of Codes parameter, see “Setting Number of Bar Codes on a Form” on page 48.

Validator Action (Error Action)

The printer response is the same whether the error stems from a bad or missing bar code. It is determined by the *Validator > Control > Validator Action* menu described on page 49. This section will provide details on each particular selection and how it affects printer operation.

Forms Printed After an Error Detection

Because of physical differences between the location of the printhead and the scanning beam, one or more forms may print after a bad form (a form with a bar code error that the validator detected).

The number of forms printed after a bad form depends on the *Media > Image > Label Length*, *Media > Speed > Print Speed*, and *Media > Speed > Slew Speed* settings. Shorter forms and faster speeds tend to increase the number of forms printed before the validator has a chance to detect an error. Also, the validator may not detect an error on forms that have bar codes near the bottom of the form until the next form has already started printing.

Forms that print after a bad form are treated differently, depending upon the error action mode selected (see Table 5). Modes that require a reprint operation may need to reprint more than just the bad form.

Table 5. Actions Done to Forms following a Bad Form

Validator Action	Action to Forms after a Bad Form
Stop	Tagged as failed, even though it was never scanned.
Overstrike	Overstruck.
Retry Form	Overstruck and reprinted (default).
Stop & Retry	Reprinted.
Grade&Report	Not applicable (all forms are scanned once).
Rescan Form	Scanned. If error persists, it will be rescanned and overstruck.
Rescan&Retry	Scanned. If error persists, it will be overstruck and reprinted.
Rescan&Stop	Scanned. If error persists, it will be tagged as failed, even though it was never scanned.

Stop

If the validator detects a bar code failure, the print job stops, the printer status indicator lamp flashes, the alarm sounds, and the appropriate error message displays.

The printer remains in a fault condition until you press the PAUSE key. This clears the error message and takes the printer OFFLINE. You must correct any condition that may have caused the fault. When ready, the printer can be put back ONLINE and it will resume printing with the form immediately following the bad form and any other forms printed prior to the physical stop (see “Forms Printed After an Error Detection” on page 71).

Overstrike

Use Overstrike mode when you want bad labels to be marked, but not reprinted (i.e., when using pre-numbered labels).

If the system detects a bar code failure, the print job stops, the printer status indicator lamp flashes, the alarm sounds, and the appropriate error message displays.

Without pausing, the printer then automatically reverses to the top of the bad form. It then prints an obliterating pattern over the bad form and any other forms printed prior to the physical stop (see “Forms Printed After an Error Detection” on page 71). By default, the obliterating pattern is a grid of fine lines which clearly marks the label as bad but allows you to read what was originally printed.

IMPORTANT T6000 printers have limited backup and therefore limited overstrike distance of about one (1) inch.

The *Validator > Control > Overstrike Style* options are: Grid, Grey, Checkerboard, or Error Type Msg. Select “Error Type Message” to see the error message printed on the bad form as the Overstrike Style.

IMPORTANT If you are using an RFID encoder, set the *Validator > Control > Overstrike Style* different than the *RFID > Control > Overstrike*. This will help you differentiate between a validator error and an RFID error.

After the overstrike printing, the printer clears the error message and stops the alarm, then resumes normal printing at the point the job was stopped.

If more than one form is overstruck, only the first overstruck form is lost (the one with the missing or bad bar code), and a separate print command is required to resend it from the host, if needed. The rest of the overstruck forms are automatically resent.

Retry Form

This mode is similar to the Overstrike mode. However, instead of resuming printing where the printer had left off, the printer will attempt to reprint the bad form. The number of times the printer will attempt to reprint the bad form is determined by the *Validator > Control > Num Retry* setting

The printer will stop, indicate an error, and overstrike as described on page 72. Then it will skip a number of blank labels, depending on the setting for *Validator > Control > Skip Labels*. It will then slew to the next top of a blank form and reprint the bad form and any other overstruck forms (see “Forms Printed After an Error Detection” on page 71).

Once the *Validator > Control > Num Retry* counter has been exhausted, the print job stops completely. After you clear the error message, the printer will print the same label or the next label, depending on the setting for *Validator > Control > Max Retry Action*.

Stop & Retry

This mode is similar to the Stop mode: the printer will stop printing and display the error message. After you clear the error message, it will then skip a number of blank labels, depending on the setting for *Validator > Control > Skip Labels*. Then it will slew to the next top of a blank form and reprint the bad form and any other forms printed prior to the physical stop (see “Forms Printed After an Error Detection” on page 71).

NOTE: The number of times the printer will attempt to reprint the bad form is determined by the *Validator > Control > Num Retry* setting.

The printer will stop after the specified *Validator > Control > Num Retry* attempts. After you clear the error message, the printer will print the same label or the next label, depending on the setting for *Validator > Control > Max Retry Action*.

Grade&Report

In this mode, the entire print job will print uninterrupted. If one or more errors is detected, the printer status indicator lamp flashes, the alarm sounds, and the error message “Bar code fails / Job has errors” displays.

IMPORTANT The error message lets you know that at least one bad form printed. To determine which form(s) are bad, you must manually scan all of them.

The printer remains in a fault condition until you press the PAUSE key. This clears the error message and takes the printer OFFLINE. Correct any condition that may have caused the fault, then press PAUSE to place the printer back ONLINE.

Rescan Form (T8000 only)

This mode is similar to the Retry Form mode, however, instead of backing up and overstriking the form, the printer will back up and rescan the bad form and any other forms that have already printed (see “Forms Printed After an Error Detection” on page 71).

NOTE: The number of times the printer will attempt to rescan the form and following forms is determined by the *Validator > Control > Num Rescan* setting.

If the printer scans these forms correctly on any of the rescans, it will continue printing with the next form.

If the printer fails to scan these forms correctly on all of the rescans, it will overstrike the forms, stop, and indicate an error similar to Stop mode. After you clear the error message, the printer will skip a number of blank labels, depending on the setting for *Validator > Control > Skip Labels*.

It will then slew to the next top of a blank form and reprint the same form or go the next form, depending on the setting for *Validator > Control > Max Retry Action*.

NOTE: The only difference between Rescan Form and Rescan&Stop is that when a form still fails after all the rescans, Rescan Form will overstrike the bad form, whereas Rescan&Stop will not.

Rescan&Retry (T8000 only)

This mode is similar to Rescan Form with one exception: after the printer has rescanned the form and overstruck it, if there was still a fault, it will reprint and rescan the same form again.

NOTE: The number of times the printer will attempt to rescan the form is determined by the *Validator > Control > Num Rescan* setting.

The number of times the printer will attempt to *reprint* the bad form is determined by the *Validator > Control > Num Retry* setting.

If the printer scans these forms correctly on any of the rescans or reprints, it will continue printing with the next form.

If the printer fails to scan these forms correctly on all of the rescans and reprints, it will overstrike the forms, stop, and indicate an error similar to Stop mode. After you clear the error message, the printer will skip a number of blank labels, depending on the setting for *Validator > Control > Skip Labels*.

It will then slew to the next top of a blank form and reprint the same form or go the next form, depending on the setting for *Validator > Control > Max Retry Action*.

Rescan&Stop (T8000 only)

This mode is similar to the Retry Form mode, however, instead of backing up and overstriking the form, the printer will back up and rescan the bad form and any other forms that have already printed (see “Forms Printed After an Error Detection” on page 71).

NOTE: The number of times the printer will attempt to rescan the form and following forms is determined by the *Validator > Control > Num Rescan* setting.

If the printer scans these forms correctly on any of the rescans, it will continue printing with the next form.

If the printer fails to scan these forms correctly on all of the rescans, it will stop and indicate an error similar to Stop mode. After you clear the error message, the printer will skip a number of blank labels, depending on the setting for *Validator > Control > Skip Labels*.

It will then slew to the next top of a blank form and reprint the same form or go to the next form, depending on the setting for *Validator > Control > Max Retry Action*.

NOTE: The only difference between Rescan Form and Rescan&Stop is that when a form still fails after all the rescans, Rescan Form will overstrike the bad form, whereas Rescan&Stop will not.

Error Messages

The validator can detect a number of errors. When one of these errors occurs, the validator alerts the printer to perform the currently selected error action (see “Validator Action (Error Action)” on page 71) and show the appropriate error message on the printer display. Validator error messages are explained in Table 6.

Table 6. Message List

Displayed Message	Solution/Explanation
<p>Bar code fails Job has errors</p>	<p>This message appears when at least one label in a batch of labels has a data validation error and Validator Action is set to Grade&Report.</p> <ol style="list-style-type: none"> 1. Press PAUSE to clear the message. 2. Manually scan all the bar codes in the label batch, then reprint the bad labels
<p>Bar Code Improper Data Format</p>	<p>Data validation error: the bar code is not properly encoded. For example, a check sum is incorrect, a required number of characters is not met, or the required terminator characters are not included. This problem is almost always caused by incorrect form or host application design.</p> <ol style="list-style-type: none"> 1. Fix the application so it sends data in the correct bar code format.
<p>Bar code quiet zone too small</p>	<p>Data validation error: the blank zone(s) left or right of the bar code is not big enough to meet the minimum requirement. Typically, this occurs in forms where bar codes are placed too close to other elements, the bar code is too close to an edge of the media, or the media’s position is shifting. The minimum quiet zone on each end of the bar code should be ten times the minimum element width or 1/4 inch, whichever is greater. In addition, between bar codes, the validator requires a minimum distance of 20 times the minimum element width or 1/2 inch, whichever is greater.</p> <ol style="list-style-type: none"> 1. Fix the application. 2. Disable <i>Validator > Control > Quiet Zone</i> menu.
<p>Calibration warning</p>	<p>The validator has detected that it needs calibration. This message is a reminder and does not halt printing.</p> <ol style="list-style-type: none"> 1. Press PAUSE to clear the message. Calibrate the validator. See “Calibration” on page 39.

Table 6. Message List

Displayed Message	Solution/Explanation
Checksum Failure	<p>The bar code data fails the checksum check or is missing the checksum digit.</p> <ol style="list-style-type: none"> 1. Verify that the checksum digit exists in the bar code and that it is the correct value.
<p>Contrast too low Check media</p>	<p>Data validation error: the contrast between bars and spaces is not sufficient. This can be caused by too little heat in the thermal transfer or by use of colored media or ribbons.</p> <ol style="list-style-type: none"> 1. Increase <i>Media > Image > Print Intensity</i> or reduce <i>Media > Speed > Print Speed</i> by menu or host software, change media, or set <i>Validator > Grading > Symbol Contrast</i> to 0% (to disable it).
<p>ODV COMM ERR See Manual</p>	<p>Communication error between printer and online data validator (ODV).</p> <ol style="list-style-type: none"> 1. Cycle power. 2. If the problem persists, contact your authorized customer service representative.
<p>Overall Grade Fail</p>	<p>Overall data validation failure: decodeability, percent decode, defects, modulation, EC Min, Rmin, and/or Symbol Contrast.</p> <ol style="list-style-type: none"> 1. Press PAUSE to clear the message. 2. Adjust the parameter that is causing the failure. To see which parameter is failing, run a Scan Report (page 61). 3. Lower the <i>Validator > Grading > Overall Grade</i> to a point where the worst parameter grade will be above the Overall Grade threshold.
<p>Poor scanning Check heat&head</p>	<p>Data validation failure: decodeability. The difference between wide and narrow elements is too close for the validator to reliably discern. This usually indicates an improperly set heat/speed/pressure combination or the loss of a printhead element.</p> <ol style="list-style-type: none"> 1. Adjust <i>Media > Image > Print Intensity</i> and <i>Media > Speed > Print Speed</i> menu or via host software. 2. Adjust the printhead pressure. (Refer to the Administrator's Manual.).

Table 6. Message List

Displayed Message	Solution/Explanation
<p>Poor scanning Check media</p>	<p>Data validation failure: percent decode. The validator detected gross inconsistencies within the height of the bar code. These types of failures are likely attributed to large blemishes within the bar code, caused by ribbon wrinkle or debris on media.</p> <ol style="list-style-type: none"> 1. Check for a wrinkled ribbon or debris on media. Roll wrinkled area onto take-up spindle. 2. Adjust the printhead pressure blocks. (Refer to the Administrator's Manual.).
<p>Poor scanning Inspect head</p>	<p>Data validation failure: hardware defect. The validator detected unexpected dark spots in spaces or light spots in bars. This usually indicates a poor ribbon/media combination, a dirty printhead, or a burned pixel.</p> <ol style="list-style-type: none"> 1. Check that paper and ribbon are clean, unwrinkled, and installed correctly. 2. Clean the printhead. 3. If message reappears, replace the printhead.
<p>Speed Exceeds Validator Limit</p>	<p>Print Speed is set above the maximum allowed for bar code printing by the validator as the Power-Up configuration with the validator option installed. An attempt was made to set <i>Media > Speed > Print Speed</i> above the maximum allowed via menu or host software. Maximum speed depends on Min. Code Height and Min. Code Gap.</p> <ol style="list-style-type: none"> 1. This message only appears briefly, and the speed is automatically reduced. 2. Make sure Min. Code Height (page 50) and Min. Code Gap (page 50) are set correctly.

Table 6. Message List

Displayed Message	Solution/Explanation
<p>Unscannable: xx Missing Codes</p>	<p>Data validation error: missing bar code. An expected bar code is missing or was printed so poorly that the validator cannot detect it.</p> <p>xx = number of bar codes missing on the form that caused the error.</p> <ol style="list-style-type: none"> 1. Check that paper and ribbon are clean, unwrinkled, and installed correctly. 2. Run a print job and check that the validator beam is not obstructed; remove obstructions as necessary. 3. Run a print job and check that the READ LED flashes as bar codes exit the printer. If the READ LED does not flash, cycle power and run the job again. If the READ LED does not flash, inspect the cables and the cable connections. If the cables are undamaged and the connections are good, replace the validator. 4. If using bitmapped bar codes, set <i>Validator > Control > Number of Codes</i> to the number of codes per form (not Auto). 5. Adjust <i>Media > Image > Print Intensity</i> and <i>Media > Speed > Print Speed</i> in the menu or via host software. 6. Make sure that <i>Validator > Scanner > Min. Read Scans</i> and <i>Validator > Control > Min. Code Height</i> are set correctly. 7. Make sure that all expected bar codes are printing. If the physical label is too small, the image may be clipped. 8. Press PAUSE to clear the message. 9. Execute the <i>Validator > Statistics > Clear Data</i> function.
<p>Validator not communicating</p>	<p>The <i>Validator > Control > Validator Active</i> is enabled in the menu, but when the printer was first powered up it could not communicate with it. Another possibility is the validator was connected to the printer and then later removed.</p> <ol style="list-style-type: none"> 1. Check that the validator signal cable is securely connected to the validator unit. 2. Disable <i>Validator > Control > Validator Active</i>. Save this setting in the <i>Configs > Control > Power-Up</i> configuration and reboot the printer.

Troubleshooting

If you are having problems with the validator, consult Table 7 for a list of symptoms and possible solutions.

Table 7. Troubleshooting the Validator

Symptom	Solution
<p>The scanning beam does not come on.</p>	<ol style="list-style-type: none"> 1. Make sure the power/data cable is plugged into the validator and the controller board on the printer. See “Installation and Removal” on page 15 or 20. 2. Make sure the validator has not been disabled in the <i>Validator > Control > Validator Active</i> menu. See “Enabling and Disabling the Validator” on page 44. 3. Print a bar code validation demo page (page 41). 4. Press the RESET button to turn the scanning beam on page 42. 5. Call your service representative if the problem persists.
<p>The scanning beam does not cover the entire width of the labels being printed.</p>	<ol style="list-style-type: none"> 1. Use <i>Validator > Scanner > Beam Shift</i> to move the beam horizontally to cover the entire width of the labels. See “Shifting the Scanning Beam” on page 39. 2. Use <i>Validator > Scanner > Beam Width</i> to adjust the width of the scanning beam. See “Beam Width” on page 60.
<p>The printer pauses after scanning each label.</p>	<p>If you have an RFID encoder but are not encoding RFID tags, make sure RFID Reader is disabled with the <i>RFID > Control > RFID Active</i> menu.</p>
<p>Printing 3 mil or 5 mil x-dimension width bar codes constantly causes error messages.</p>	<p>The validator does not recognize x-dimensions as small as 3 mil or 5 mil. If you have to print bar codes this size, disable the validator to prevent error reports. See “Enabling and Disabling the Validator” on page 44.</p>
<p>The printed labels look clean, but the validator is still reporting an error message.</p>	<p>The validator glass may be dirty, distorting the report results. Power down the printer and clean the glass using a household glass cleaner and a dry, lint-free cloth.</p>

Table 7. Troubleshooting the Validator

Symptom	Solution
The printed bar codes are causing error conditions.	<p>There are a number of factors which could be causing validation errors:</p> <ul style="list-style-type: none">• The scanning beam is not properly aligned with the two notches on the tear bar of the printer. See “Adjust the Scanning Beam” on page 35.• Make sure the entire bar code passes completely under the scanning beam.• The validator and printer are not properly communicating. Test the validator operation without using a host. See “Bar Code Validation Demo Page” on page 41.• Bar code width. The validator can recognize x-dimensions as narrow as 6.6 mil for 300 dpi printers, and 10 mil for 203 dpi printers. The validator cannot recognize x-dimensions smaller than 6.6 mil or larger than 40 mil.• Bar code size. A minimum height of 1/8 inch is required for validation. If problems persist, increase the bar code height.

Table 7. Troubleshooting the Validator

Symptom	Solution
<p>The printed bar codes are causing error conditions. (continued)</p>	<ul style="list-style-type: none"> • Bar code type. The validator only recognizes the following linear, picket fence bar codes: Codabar, Code 39, Code 93, Code 128, Interleaved 2 of 5, and UPC/EAN. Stacked, 2D, and vertical (ladder) bar codes are not supported. • Bar code spacing. The validator requires a minimum distance of 1/2 inch or 20 times the minimum element width, whichever is greater, between bar codes. • Printer speed. See “Print Speed Limits” on page 68. If problems persist, decrease the <i>Media > Speed > Print Speed</i>. • Be sure the bar code is not printing on the extreme edges of the label. • Clean the printhead. See “Cleaning” in the <i>Administrator’s Manual</i>. • Check that paper and ribbon are clean, unwrinkled, and installed correctly. • Check the number of bar codes being validated concurrently. The validator can track the performance of up to four bar codes at one time.

Maintenance

WARNING Class 2 laser light. Do not stare into the laser beam or a reflected image of the laser beam.

WARNING Using controls, making adjustments, or performing procedures other than those specified herein may result in hazardous radiation exposure.

The validator is a self-contained unit that requires only periodic cleaning. Every so often, power down the printer and use a household glass cleaner and a dry, lint-free cloth to clean the glass.

If the problem with the printer is not fixed by one of these troubleshooting methods, call your authorized service representative or the Printronix Customer Support Center. See “Contact Information” on page 82.

A **Contact Information**

Printronix Customer Support Center

IMPORTANT Please have the following information available prior to calling the Printronix Customer Support Center:

- Model number
- Serial number (located on the back of the printer)
- Installed options (i.e., interface and host type if applicable to the problem)
- Configuration printout: Refer to the *Administrator's Manual*.
- Is the problem with a new install or an existing printer?
- Description of the problem (be specific)
- Good and bad samples that clearly show the problem (faxing or emailing of these samples may be required)

Americas	(844) 307-7120 Service@PrintronixAutoID.com
Europe, Middle East, and Africa	+31 (0) 24 3030 340 EMEA_support@PrintronixAutoID.com
Asia Pacific	+886 3 990 6155 APAC_support@PrintronixAutoID.com
China	+86 755 2398 0479 CHINA_support@PrintronixAutoID.com

Printronix Auto ID Support: <http://PrintronixAutoID.com/support/>
Printronix Auto ID Consumables: <http://PrintronixAutoID.com/products/consumables/>

Corporate Offices

Printronic Auto ID

3040 Saturn Street, Suite
200, Brea, CA 92821
U.S.A.

Phone: (844) 307-7120
Fax: (657) 258-0817

Printronic Auto ID, EMEA Head Office

Georg-Wimmer-Ring 8b D-85604 Zorneding
Germany

Phone: +49 (0) 8106 37979-23
Fax: +49 (0) 8106 37979-05

Printronic Auto ID, Asia Pacific Head Office

Taiwan
9F, No. 95, Minquan Rd.
Xindian Dist., New Taipei City
231 Taiwan (R.O.C)

Phone: +886 3 990 6155
Fax: +886 3 990 6215

Printronic Auto ID, China Head Office

Shenzhen
New World Center 2510 room
No. 6009, Yitian road
Futian District, Shenzhen
518000
China

Phone: +86 755 2398 0479
Fax: +86 755 2398 0773

Visit the Printronix web site at www.PrintronixAutoID.com